

**P7500 Series
TriMode™ Probes
Technical Reference**



077-2161-02

Tektronix

**P7500 Series
TriMode™ Probes
Technical Reference**

Revision A

www.tektronix.com

077-2161-02

Tektronix

Copyright © Tektronix. All rights reserved. Licensed software products are owned by Tektronix or its subsidiaries or suppliers, and are protected by national copyright laws and international treaty provisions.

Tektronix products are covered by U.S. and foreign patents, issued and pending. Information in this publication supersedes that in all previously published material. Specifications and price change privileges reserved.

TEKTRONIX and TEK are registered trademarks of Tektronix, Inc.

TriMode is a trademark of Tektronix, Inc.

Velcro is a registered trademark of Velcro Industries B.V.

G3PO is a trademark of Corning Gilbert Inc.

Contacting Tektronix

Tektronix, Inc.
14200 SW Karl Braun Drive
P.O. Box 500
Beaverton, OR 97077
USA

For product information, sales, service, and technical support:

- In North America, call 1-800-833-9200.
- Worldwide, visit www.tektronix.com to find contacts in your area.

Warranty

Tektronix warrants that this product will be free from defects in materials and workmanship for a period of one (1) year from the date of shipment. If any such product proves defective during this warranty period, Tektronix, at its option, either will repair the defective product without charge for parts and labor, or will provide a replacement in exchange for the defective product. Parts, modules and replacement products used by Tektronix for warranty work may be new or reconditioned to like new performance. All replaced parts, modules and products become the property of Tektronix.

In order to obtain service under this warranty, Customer must notify Tektronix of the defect before the expiration of the warranty period and make suitable arrangements for the performance of service. Customer shall be responsible for packaging and shipping the defective product to the service center designated by Tektronix, with shipping charges prepaid. Tektronix shall pay for the return of the product to Customer if the shipment is to a location within the country in which the Tektronix service center is located. Customer shall be responsible for paying all shipping charges, duties, taxes, and any other charges for products returned to any other locations.

This warranty shall not apply to any defect, failure or damage caused by improper use or improper or inadequate maintenance and care. Tektronix shall not be obligated to furnish service under this warranty a) to repair damage resulting from attempts by personnel other than Tektronix representatives to install, repair or service the product; b) to repair damage resulting from improper use or connection to incompatible equipment; c) to repair any damage or malfunction caused by the use of non-Tektronix supplies; or d) to service a product that has been modified or integrated with other products when the effect of such modification or integration increases the time or difficulty of servicing the product.

THIS WARRANTY IS GIVEN BY TEKTRONIX WITH RESPECT TO THE PRODUCT IN LIEU OF ANY OTHER WARRANTIES, EXPRESS OR IMPLIED. TEKTRONIX AND ITS VENDORS DISCLAIM ANY IMPLIED WARRANTIES OF MERCHANTABILITY OR FITNESS FOR A PARTICULAR PURPOSE. TEKTRONIX' RESPONSIBILITY TO REPAIR OR REPLACE DEFECTIVE PRODUCTS IS THE SOLE AND EXCLUSIVE REMEDY PROVIDED TO THE CUSTOMER FOR BREACH OF THIS WARRANTY. TEKTRONIX AND ITS VENDORS WILL NOT BE LIABLE FOR ANY INDIRECT, SPECIAL, INCIDENTAL, OR CONSEQUENTIAL DAMAGES IRRESPECTIVE OF WHETHER TEKTRONIX OR THE VENDOR HAS ADVANCE NOTICE OF THE POSSIBILITY OF SUCH DAMAGES.

[W2 – 15AUG04]

Table of Contents

General Safety Summary	v
Preface	vii
Products Covered	vii
Theory of Operation	1
Input Voltage Limits	1
TriMode Operation	5
Probing Techniques to Maximize Signal Fidelity	7
Input Impedance and Probe Loading	15
Reference	17
Single-Ended Measurements Using A and B Modes	17
Differential Measurements	19
Serial Bus Standards	21
Specifications	22
Warranted Characteristics	22
Typical Characteristics	23
Nominal Characteristics	26
Tip Specifications	27
User Service	35
Error Condition	35
Replaceable Parts	36
Preparation for Shipment	48

List of Figures

Figure 1: Operating voltage window	2
Figure 2: Dynamic range versus linearity, 5X range (P7513 & P7516).....	3
Figure 3: Dynamic range versus linearity, 12.5X range (P7513 & P7516)	3
Figure 4: Dynamic range versus linearity, 5X range (P7520)	4
Figure 5: Dynamic range versus linearity, 12.5X range (P7520).....	4
Figure 6: TriMode input structure	6
Figure 7: Typical TriMode Probe Setup screen	6
Figure 8: P75TLRST TriMode Long Reach Solder Tip.....	7
Figure 9: TriMode Resistor solder tips.....	8
Figure 10: Typical wire length from probe tip to circuit	9
Figure 11: P75TLRST solder tip with 0.010 in. of tip wire	10
Figure 12: P75TLRST solder tip with 0.050 in. of tip wire	10
Figure 13: P75TLRST solder tip with 0.100 in. of tip wire	11
Figure 14: P75TLRST solder tip with 0.200 in. of tip wire	11
Figure 15: P75PDPM Precision Differential Probing Module	12
Figure 16: P75PDPM with short ground spring, 0.030 in. spacing.....	13
Figure 17: P75PDPM with short ground spring, 0.050 in. spacing.....	13
Figure 18: P75PDPM with short ground spring, 0.090 in. spacing.....	14
Figure 19: P75PDPM with short ground spring, 0.180 in. spacing.....	14
Figure 20: TriMode probe input model	15
Figure 21: TriMode probe high frequency input impedance model	15
Figure 22: Embedded probe fixture	16
Figure 23: Typical channel isolation for P7500 Series TriMode probes	18
Figure 24: Simplified model of a differential amplifier	19
Figure 25: Typical CMRR for P7500 Series TriMode probes.....	20
Figure 26: Probe body and control box dimensions	25
Figure 27: P75TLRST TriMode Long Reach Solder Tip dimensions	27
Figure 28: TriMode probe with the P75TLRST solder tip.....	28
Figure 29: P75TLRST differential impedance	28
Figure 30: TriMode Resistor solder tip dimensions	29
Figure 31: Step response with the TriMode Resistor solder tip	30
Figure 32: TriMode Resistor solder tip differential impedance	30
Figure 33: TriMode Extended Resistor solder tip dimensions	31
Figure 34: Step response with the TriMode Extended Resistor solder tip	32
Figure 35: TriMode Extended Resistor solder tip differential impedance	32
Figure 36: P75PDPM Precision Differential Probing Module dimensions	33
Figure 37: TriMode probe with the P75PDPM probing module	34
Figure 38: P75PDPM differential impedance	34

Figure 39: Removing the bullets.....	37
Figure 40: Installing the bullets.....	38
Figure 41: Large and small springs installed	40
Figure 42: Set the gap.....	41
Figure 43: Insert tool beneath spring.....	41
Figure 44: Transfer spring from tip to tool	42
Figure 45: Place spring on tool	43
Figure 46: Set spring in front seat	43
Figure 47: Set the spring in the rear seats.....	44
Figure 48: Properly seated spring.....	44
Figure 49: Disconnecting the tip cable.....	45
Figure 50: Probing module tips.....	45
Figure 51: Removing the tip	46
Figure 52: Separating the tip board pair	46
Figure 53: Seating the tip in the top tabs.....	47
Figure 54: Snapping the tip into the bottom tabs	47

List of Tables

Table i: TriMode probes	vii
Table 1: Offset ranges.....	17
Table 2: Serial bus standards with dynamic range requirements.....	21
Table 3: Warranted electrical characteristics	22
Table 4: Typical electrical characteristics.....	23
Table 5: Typical mechanical characteristics	25
Table 6: Nominal electrical characteristics	26
Table 7: TriMode probes replaceable parts	36
Table 8: Required equipment.....	36

General Safety Summary

Review the following safety precautions to avoid injury and prevent damage to this product or any products connected to it.

To avoid potential hazards, use this product only as specified.

Only qualified personnel should perform service procedures.

While using this product, you may need to access other parts of a larger system. Read the safety sections of the other component manuals for warnings and cautions related to operating the system.

To Avoid Fire or Personal Injury

Connect and Disconnect Properly. Connect the probe output to the measurement instrument before connecting the probe to the circuit under test. Connect the probe reference lead to the circuit under test before connecting the probe input. Disconnect the probe input and the probe reference lead from the circuit under test before disconnecting the probe from the measurement instrument.

Observe All Terminal Ratings. To avoid fire or shock hazard, observe all ratings and markings on the product. Consult the product manual for further ratings information before making connections to the product.

Do not apply a potential to any terminal, including the common terminal, that exceeds the maximum rating of that terminal.

Do Not Operate Without Covers. Do not operate this product with covers or panels removed.

Do Not Operate With Suspected Failures. If you suspect that there is damage to this product, have it inspected by qualified service personnel.

Avoid Exposed Circuitry. Do not touch exposed connections and components when power is present.

Do Not Operate in Wet/Damp Conditions.

Do Not Operate in an Explosive Atmosphere.

Keep Product Surfaces Clean and Dry.

Terms in this Manual These terms may appear in this manual:



WARNING. *Warning statements identify conditions or practices that could result in injury or loss of life.*



CAUTION. *Caution statements identify conditions or practices that could result in damage to this product or other property.*

Symbols and Terms on the Product

These terms may appear on the product:

- DANGER indicates an injury hazard immediately accessible as you read the marking.
- WARNING indicates an injury hazard not immediately accessible as you read the marking.
- CAUTION indicates a hazard to property including the product.

The following symbol(s) may appear on the product:



CAUTION
Refer to Manual

Preface

This manual discusses topics that are not covered in depth in the *P7500 Series TriMode Probes Quick Start User Manual*.

The main sections are:

- Theory of Operation — Contains probe details not covered in the user manual.
- Reference — Contains information about differential measurements and how to increase measurement accuracy.
- Specifications — Contains warranted, typical, and nominal characteristics for the probe and probe tip accessories.
- User Service — Describes troubleshooting and probe maintenance.

Products Covered

The table below lists the TriMode probes covered by this manual.

Table i: TriMode probes

Probe model	Serial number
P7513	B020000 and above ¹
P7516	B020000 and above ¹
P7520	All

¹ For information on probes with serial numbers below B020000, refer to the P7500 Series TriMode Probes Technical Reference in the previous edition of the Product Documentation (Tektronix part number 020-2790-00). You can also access the manual at www.tektronix.com/manuals.

Theory of Operation

This section discusses operating considerations and probing techniques. For more detailed information about differential measurements and TriMode operation, refer to *Reference*. (See page 17.)

The P7500 Series TriMode probes are optimized for high bandwidth; they are not general-purpose probes. The probe tips are miniaturized for electrical characteristics and access to dense circuitry, and must be handled carefully.



CAUTION. *To prevent damage to the probe, use care when handling the probe. Rough or careless use can damage the probe.*

Input Voltage Limits

The P7500 Series TriMode probes are designed to probe low-voltage circuits. Before probing a circuit, take into account the limits for maximum input voltage, the operating voltage window, and the differential-mode signal range. (See Table 4 on page 23.)

Maximum Input Voltage

The maximum input voltage is the maximum voltage to ground that the inputs can withstand without damaging the probe input circuitry.



CAUTION. *To avoid damaging the inputs of the probes, do not apply more than ± 15 V (DC + peak AC) between each input or between either probe input and ground.*



CAUTION. *To avoid ESD damage to the probe, always use an antistatic wrist strap (provided with your probe), and work at a static-approved workstation when you handle the probe.*

Operating Voltage Window

The operating voltage window defines the maximum voltage that you can apply to each input, with respect to earth ground, without saturating the probe input circuitry. (See Figure 1.) A common-mode voltage that exceeds the operating voltage window may produce an erroneous output waveform even when the differential-mode specification is met.

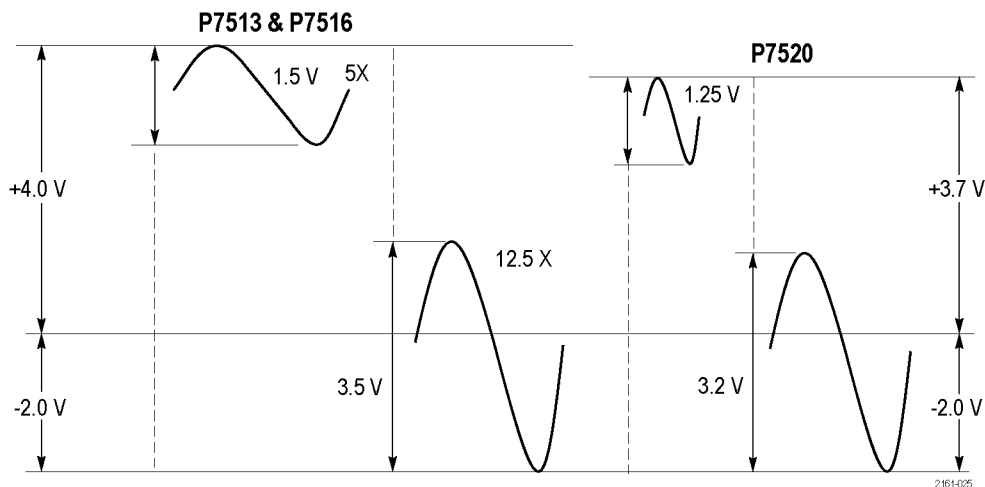

Figure 1: Operating voltage window

Differential-Mode Signal Range

The differential-mode signal range is the maximum voltage difference between the A and B inputs that the probe can accept without distorting the signal. The distortion from a voltage that exceeds this maximum can result in a clipped or otherwise inaccurate measurement. The P7500 Series probes have two attenuation settings, 5X and 12.5X, that allow dynamic range to be traded off against signal noise. The 12.5X attenuator setting has the largest dynamic range; the 5X attenuator setting has the lowest noise. The graphs on the following pages illustrate the linearity error over the dynamic voltage range of the probes in both attenuation settings.

Offset Voltage Range

The Offset Voltage Control, accessible from the attached oscilloscope user interface, allows the probe dynamic range to be effectively moved up and down within the limits of the offset voltage range and the operating voltage window. When the offset voltage is set to zero volts and the input signal is zero volts (inputs shorted to ground, not open), the displayed signal should be zero volts. If a noticeable zero volt offset is present under the above conditions, a Probe Cal operation should be performed. (See the *P7500 Series Probes Quick Start User Manual*).

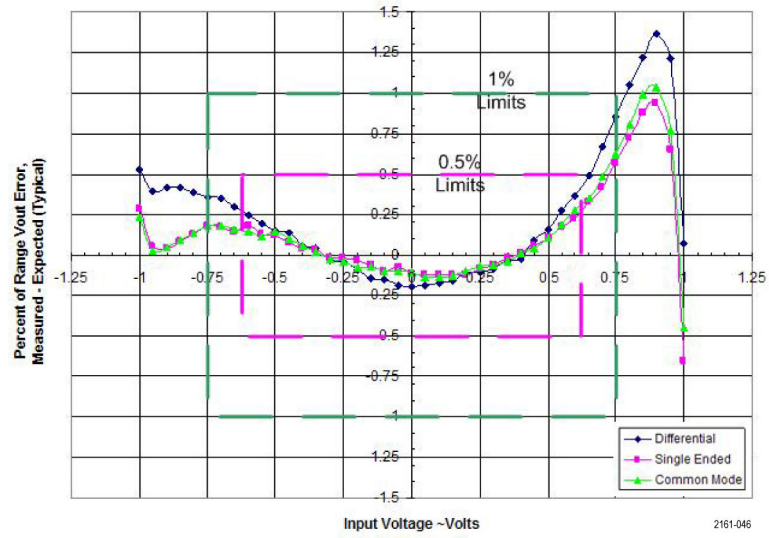

Figure 2: Dynamic range versus linearity, 5X range (P7513 & P7516)

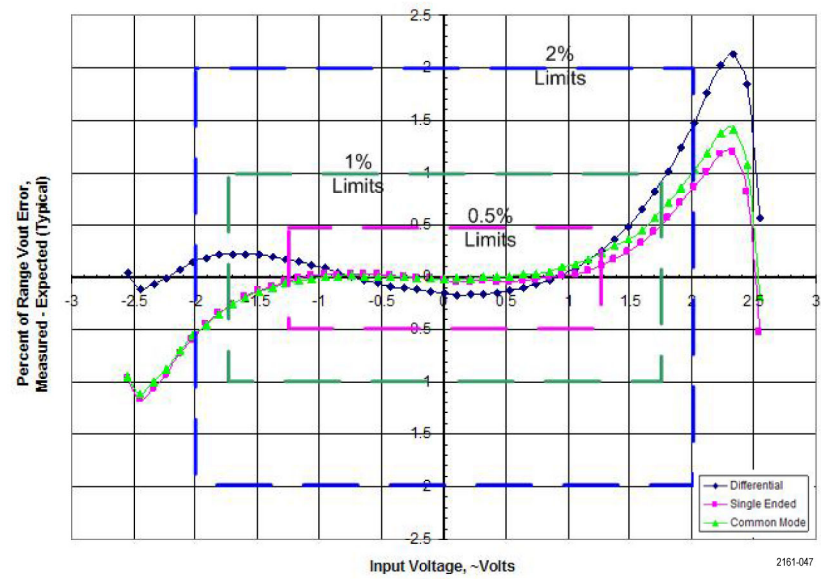

Figure 3: Dynamic range versus linearity, 12.5X range (P7513 & P7516)

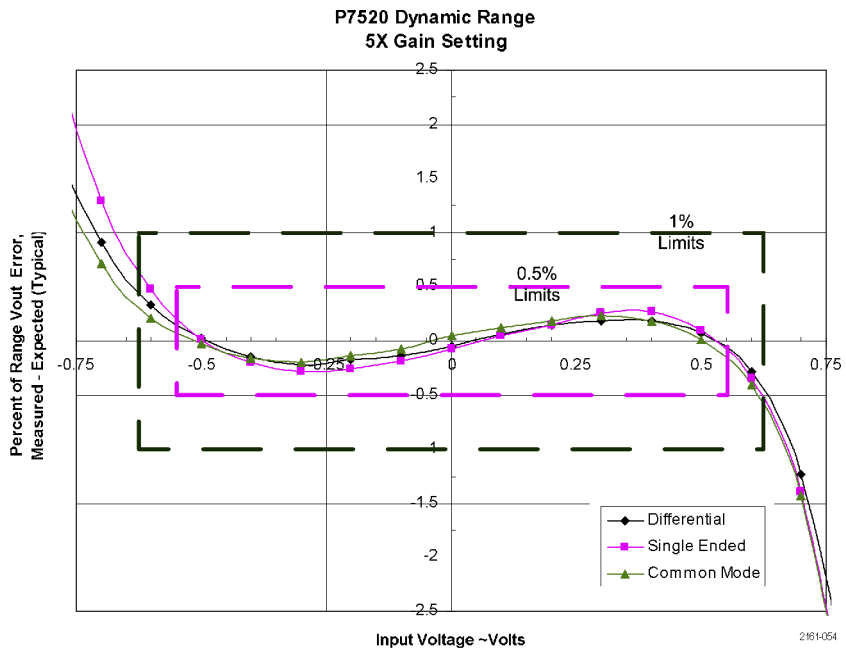

Figure 4: Dynamic range versus linearity, 5X range (P7520)

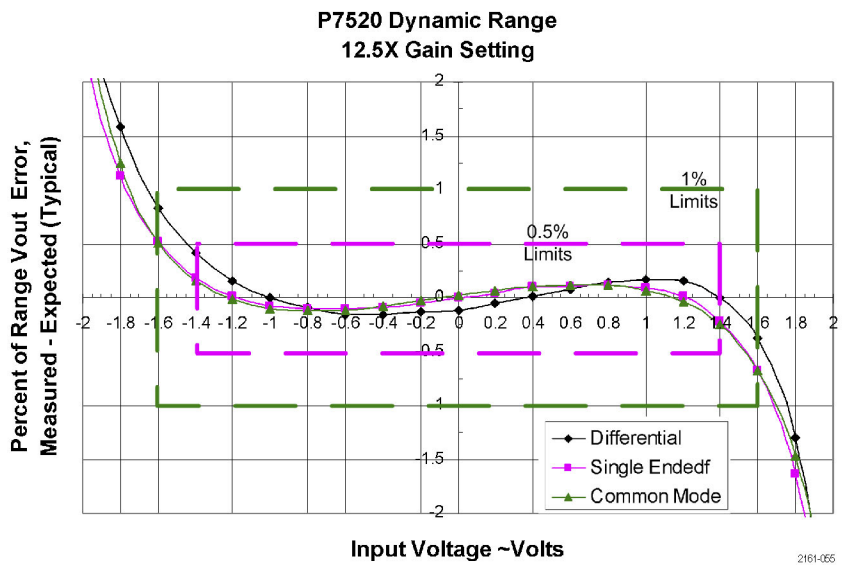

Figure 5: Dynamic range versus linearity, 12.5X range (P7520)

TriMode Operation

The TriMode feature of the new P7500 Series probe family is designed for improved convenience and enhanced capability in measuring differential signal quality. Since a differential signal is composed of two complementary single-ended signals, full characterization of differential signal quality requires more than a simple differential measurement. A TriMode probe features three Input Modes that allow a differential signal to be fully characterized with four measurements: differential, positive polarity and negative polarity single-ended, and common mode.

A TriMode probe provides improved efficiency and convenience by enabling full differential signal characterization from a single soldered connection. Using one of the solder tips available for the TriMode probes, (for example, the P75TLRST probe tip), probe connections are soldered to the two complementary signals (the A signal and the B signal) and a ground reference. From this single DUT (device under test) connection, the internal electronic switching control of the TriMode probe allows any one of the three probe Input Modes (four measurements) to be selected at a time. The TriMode probe inputs are routed on the probe ASIC (application-specific integrated circuit) to a set of four independent input amplifiers that perform the following signal calculations:

- $A - B$ (for differential signal measurement)
- $A - \text{GND}$ (for positive polarity single-ended measurement)
- $B - \text{GND}$ (for negative polarity single-ended measurement)
- $[A+B]/2 - \text{GND}$ (for common mode measurement)

NOTE. *In the B – GND Mode, the negative polarity B input is not inverted.*

The four input amplifiers are multiplexed together and only the selected Input Mode function is output to the connected oscilloscope. (See Figure 6 on page 6.) The figure shows a conceptual view of the TriMode probe input structure, where the C input provides the probe ground reference and is connected to the probe tip ground interconnect using the probe tip cable coaxial shields.

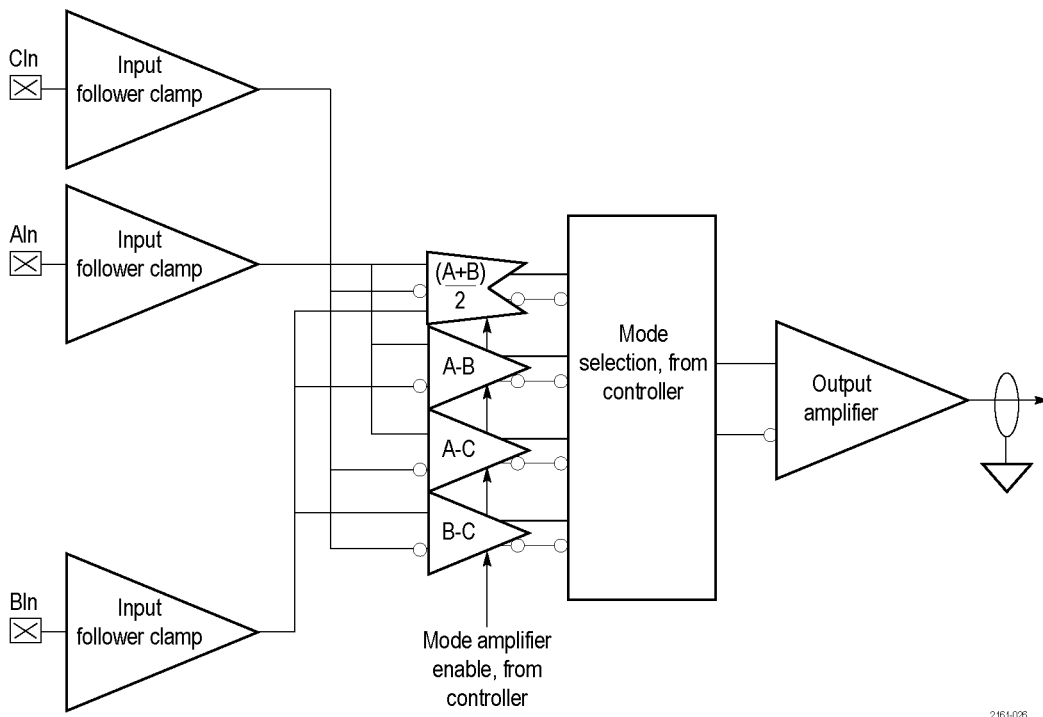

Figure 6: TriMode input structure

On oscilloscopes that do not provide full TriMode support, the TriMode features are controlled by the probe Control Box switches, which allow oscilloscope features like Probe Cal to be exercised only for the selected probe Input Mode.

On oscilloscopes that provide full TriMode support, the oscilloscope-controlled probe GUI (graphical-user interface) can perform a Probe Cal operation on all Input Modes and Attenuation Settings at once using the TriMode Probe Cal fixture that is supplied with P7500 Series probes. (See the *P7500 Series Quick Start User Manual* for instructions on running the Probe Cal routine.) Full TriMode support will also allow storage and automatic recall of relevant settings like Offset. (See Figure 7.)

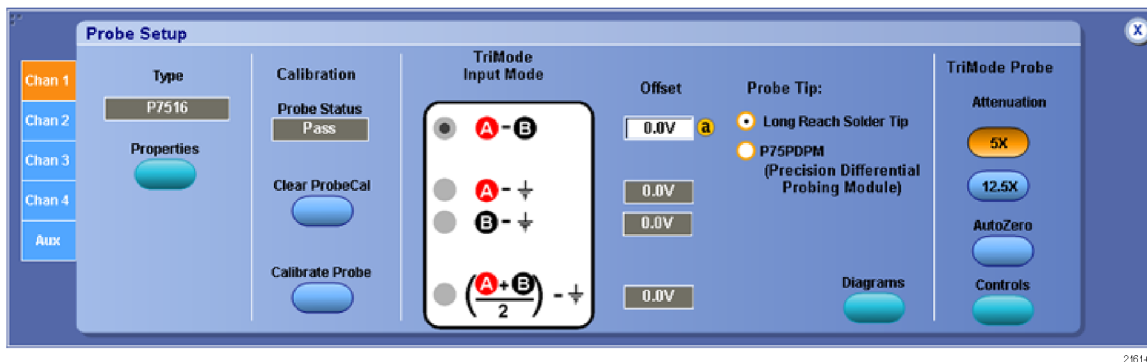

Figure 7: Typical TriMode Probe Setup screen

Probing Techniques to Maximize Signal Fidelity

Signal fidelity is an indication of how accurately a probe represents the signal being measured. The signal fidelity of the probe is best when the probe is applied properly to the circuit with the P7500 probe tips. Recommendations for connecting the P7500 probe tips are given in the following section.

P7500 TriMode Solder Tips

There are several solder tips available for connecting the P7500 Series probes to your circuit. The P75TLRST probe tip is shipped with the probes as a standard accessory. (See Figure 8.) Two resistor solder tips are available as optional accessories. (See Figure 9 on page 8.)

P75TLRST TriMode Solder Tip. The P75TLRST probe tip is composed of a small form factor interconnect circuit board with SMD0402 damping resistors and a set of vias for wire attachment to the DUT (Device Under Test). The circuit board vias are designed for both 4 mil and 8 mil wire and a special high tensile strength wire is supplied as part of the wire accessory kit. The expanded view of the probe tip shows the location of the A and B signal inputs as well as the two ground reference connections.

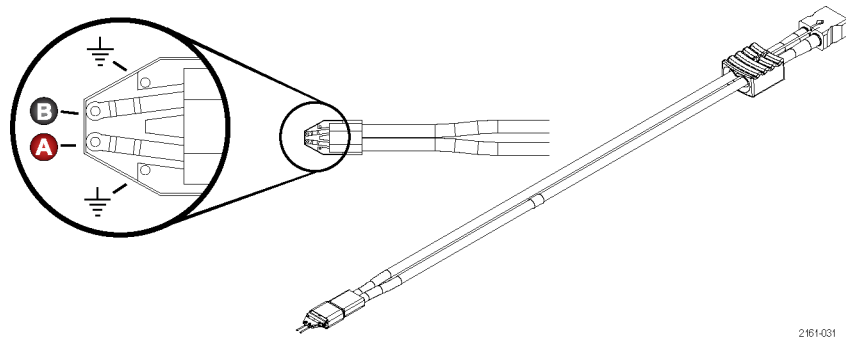

Figure 8: P75TLRST TriMode Long Reach Solder Tip

The recommended wire attachment method is to first solder the wires to the DUT, being careful to minimize the wire length of the signal and ground connections. This is followed by threading the wires through the probe tip board vias, being careful to achieve as symmetrical a wire pattern as possible between the two signal inputs and a very short ground connection. Finally, the attachment is completed by soldering the wires on top of the probe tip circuit board. Any excess wire lead length extending through the probe tip board should be removed to minimize possible signal reflection problems.

Because of the limited mechanical strength of the wire interconnect and probe tip circuit board, the solder-down probe tip should be taped down at the DUT for strain relief. Although the accessory kit includes adhesive strips that can be used for the strain relief of the probe tip, the use of mylar tape will generally provide stronger attachment if room is available at the DUT.

TriMode Resistor Solder Tips. These solder tips separate the standard 175 Ω on-board damping resistors for each probe input (+ and –) into two components. A surface mount, 75 Ω resistor is board-mounted in series with a 100 Ω leaded resistor that extends off of the tip board. The other end of the resistor is soldered to your circuit. The TriMode Extended Resistor solder tips allow a longer tip reach to your circuit under test but reduce the measurement quality.

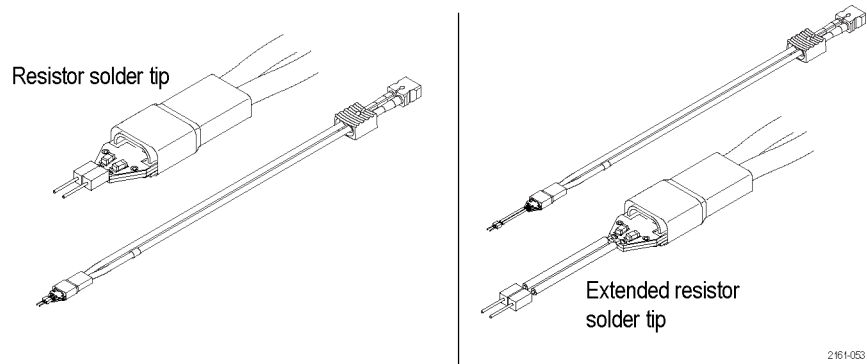

Figure 9: TriMode Resistor solder tips

Since the leads of the 100 Ω resistors take the repeated soldering cycles required when reusing the tip, they limit the need to solder directly to the tip board, extending the life of the tip. The tip resistors are replaceable and are available as a kit. (See page 36, *Replaceable Parts*.)

Probe Tip Cables and Connectors. Attached to the probe tip circuit board is a pair of very low skew (<1ps) coaxial cables and a polarized G3PO dual connector block. The 3GPO connectors use a miniature, high frequency design that enables quick and easy installation of the P75TLRST solder tip. The G3PO connector block of the probe tip is inserted into the input nose piece on the end of the probe body of the P7500 family probes. The probe body contains a mating, polarized G3PO connector block with attached G3PO connector bullets.

The connector bullets are a part of the G3PO connector design, providing a self-aligning interconnect mechanism between G3PO connectors. The G3PO connector in the probe body is designed to have higher detent force than the probe tip connectors, which is intended to ensure that the G3PO bullets remain in the probe body connector when disconnected. The probe body nose piece, with its integral spring mechanism, helps to provide a self-aligning mechanism for hand insertion of the probe tip. The probe body nose springs also give a secure capture of the probe tip connector after insertion. Release of the probe tip is assisted by using the wire-connected cable release holder on the probe tip connector. This probe tip release holder should always be used rather than pulling on the probe tip cables, which may cause tip cable damage.

DUT Connections. The lead length of the resistor leads and connection wires between the probe tip board and the DUT must be kept as short as possible to preserve the integrity of the measured signal. Typical wire lengths range from 0.010 in. to 0.100 in. (See Figure 10.)

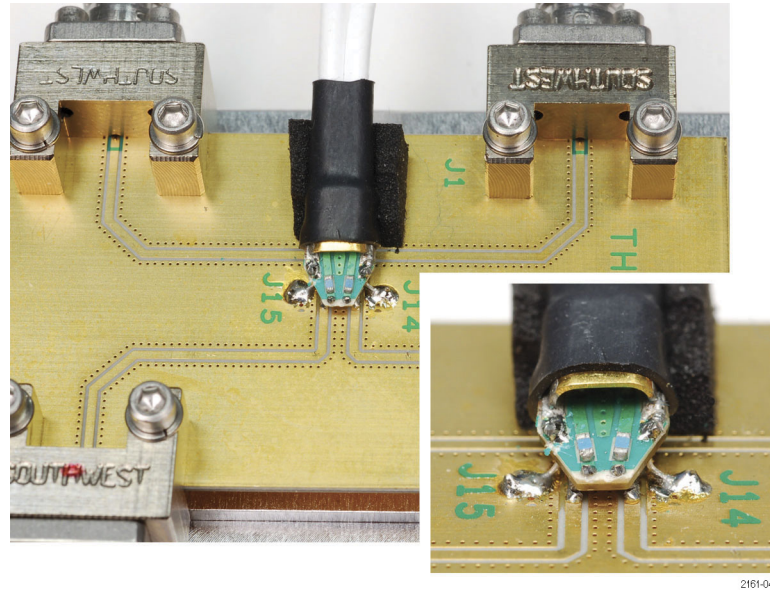

Figure 10: Typical wire length from probe tip to circuit

The following four figures illustrate the signal integrity effect on the P75TLRST solder tip when used with different lengths of tip wire. Signal fidelity is best when the wire length is kept as short as possible. The step generator that was used as a signal source for these screenshots has a 30 ps 10-90% rise time. The table in each figure contains data for two rise time measurements (10-90% and 20-80%). These screenshots can be used as a rough guide to gauge the effects of wire length, but actual results may vary depending on the other factors like characteristics of the device under test (for example, rise time and impedance), precision of the solder connection, and the model of oscilloscope.

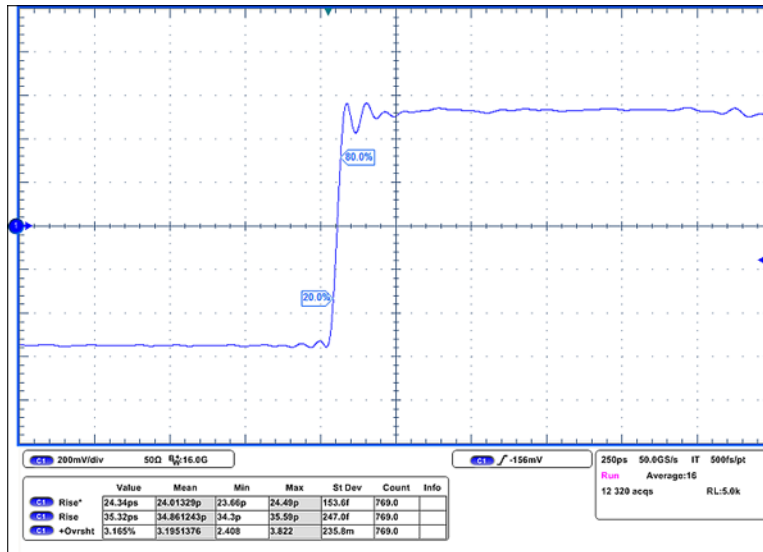

Figure 11: P75TLRST solder tip with 0.010 in. of tip wire

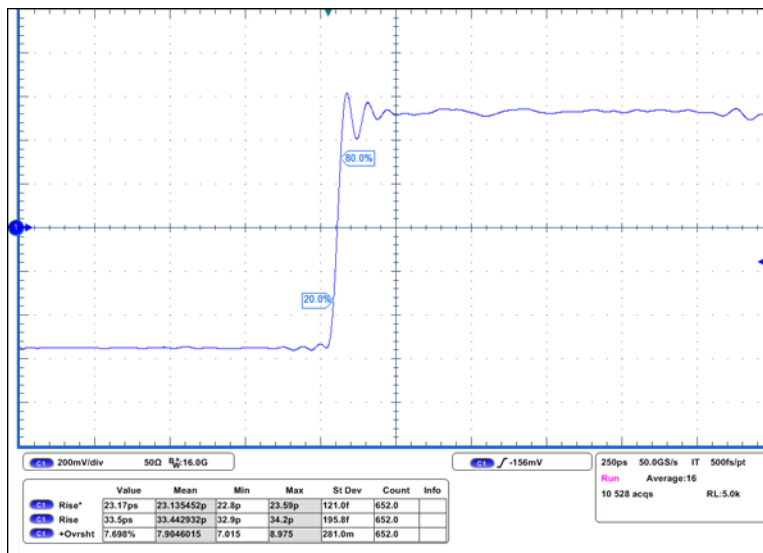

Figure 12: P75TLRST solder tip with 0.050 in. of tip wire

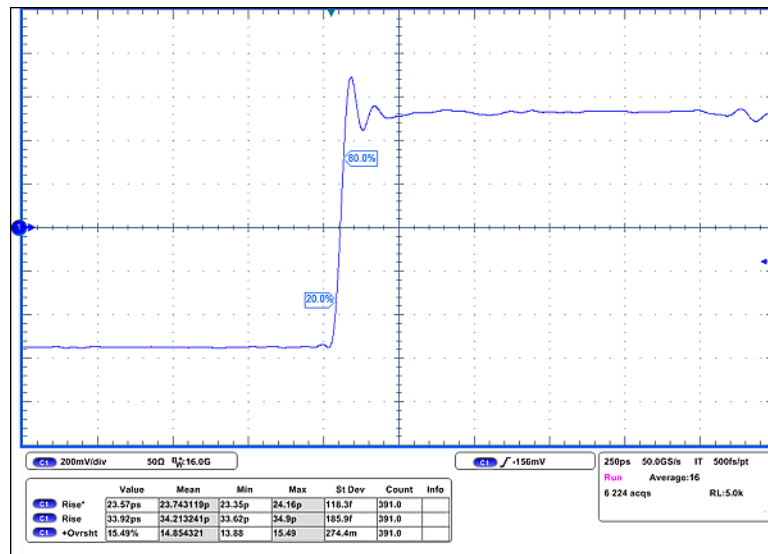

Figure 13: P75TLRST solder tip with 0.100 in. of tip wire

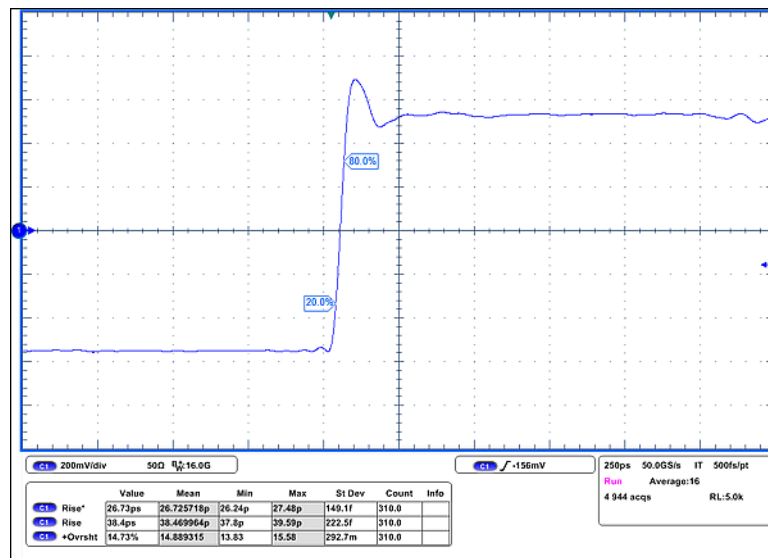

Figure 14: P75TLRST solder tip with 0.200 in. of tip wire

P75PDPM Precision Differential Probing Module

The P75PDPM Probing Module is designed for handheld and fixtured probing applications. The P75PDPM probe tip is composed of two replaceable probe tip circuit boards with a pin on one end and a G3PO socket connector on the other. Damping resistors on the tip boards near the input pins and a 50 Ω transmission line on the board transmit the signal from the input pin to the G3PO socket connector. The probe tip boards are connected to the P7500 probe body with a very low skew (<1 ps) cable assembly (P75TC).

The left-side and right-side probe tip boards mount at an angle in the P75PDPM adjustment housing. The probe tip spacing is adjustable from 0.030 – 0.180 in. (0.76 – 4.57 mm) using the thumb-operated screw. Because of the variable spacing between the two probe tip boards, a gold-plated ground spring is connected between the probe tip boards to ensure a good common mode ground return near the probe tip pins.

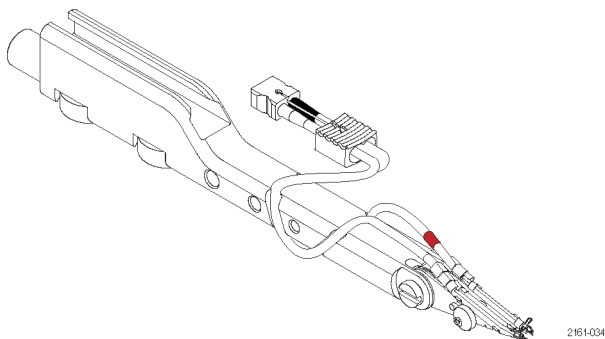

Figure 15: P75PDPM Precision Differential Probing Module

The P75PDPM probe tip circuit boards mount in an articulating metal housing that also supports the variable spacing control. The angle of the probe tip housing can be adjusted and locked in place using an articulation screw in the probe holder bar. The probe holder bar contains mechanical details for retaining the probe tip cable assembly as well as a retaining clamp for the probe body. The probe holder bar can be held manually or can be mounted for fixtured probing on an articulating probe arm using mechanical features in the holder bar.

The P75PDPM design features improved mechanical compliance in probe tip attachment to the DUT. Mechanical compliance is a significant issue for differential probes because of the difficulty in making reliable contact with two DUT connections at the same time. The reliability in making this dual point connection can be improved by a tip structure with good mechanical compliance, in which there is sufficient give in the probe tips to absorb interconnect surface irregularity.

The P75PDPM does not have a local DUT ground connection because of the great difficulty in making a good three-point interconnect without soldering. As a result, the only low-noise TriMode Input Mode available with the P75PDPM is the A-B (DIFF) mode, since for differential signals, there is an inherent virtual ground present in the measurement circuit.

The following four figures illustrate the signal integrity effect of changing the spacing on the P75PDPM Probing Module. Signal fidelity is best with the tips at the smallest spacing. The step generator that was used as a signal source for these screenshots has a 30ps 10-90% rise time. The table in each figure contains data for two rise time measurements (10-90% and 20-80%). These screenshots can be used as a rough guide to gauge the effects of probe tip spacing, but actual results may vary depending on the other factors like characteristics of the device under test (for example, rise time and impedance) and the model of oscilloscope.

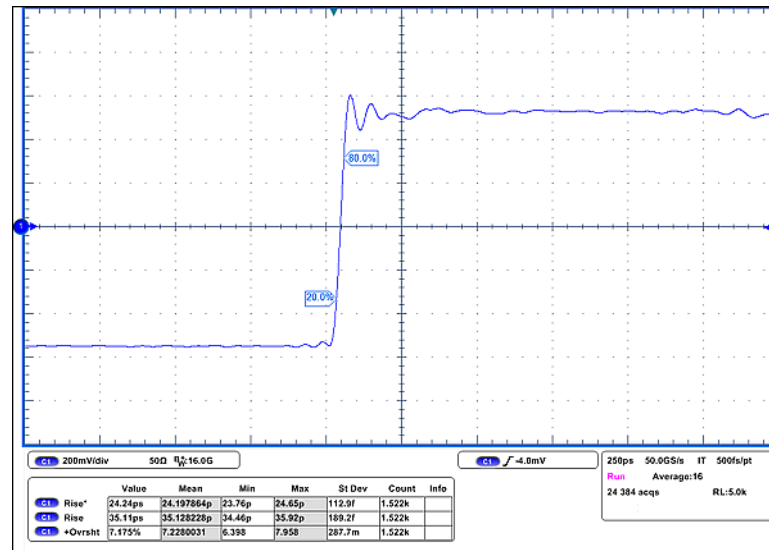

Figure 16: P75PDPM with short ground spring, 0.030 in. spacing

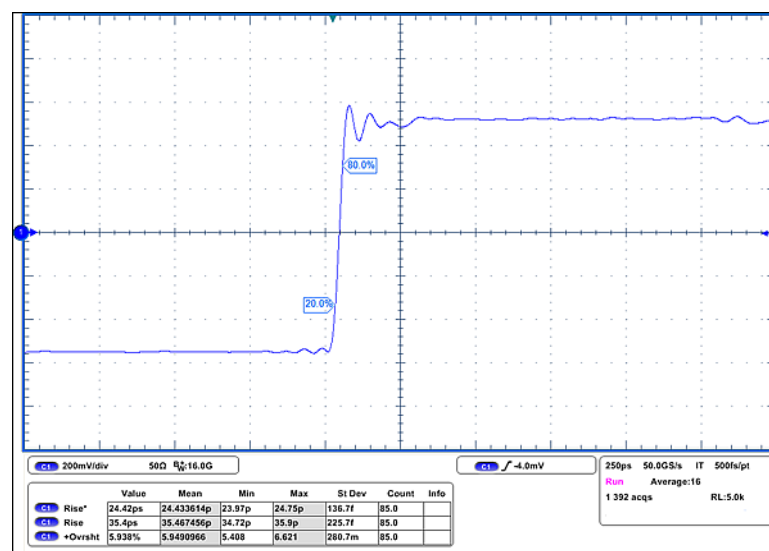

Figure 17: P75PDPM with short ground spring, 0.050 in. spacing

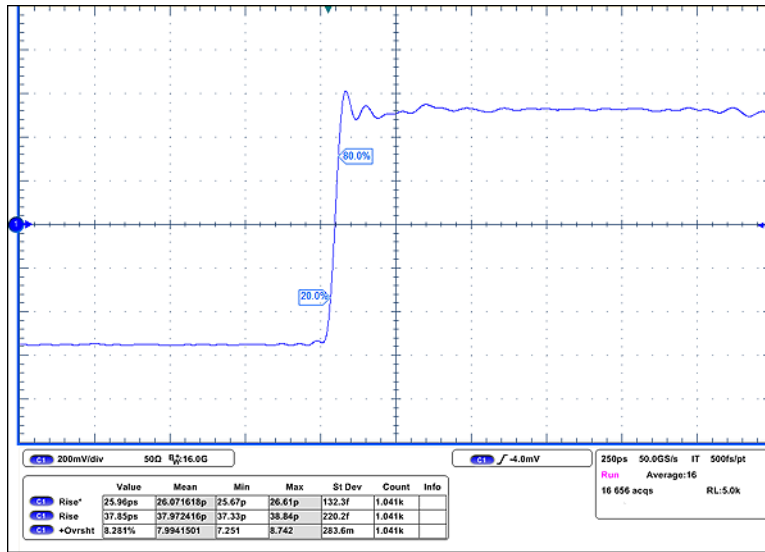

Figure 18: P75PDPM with short ground spring, 0.090 in. spacing

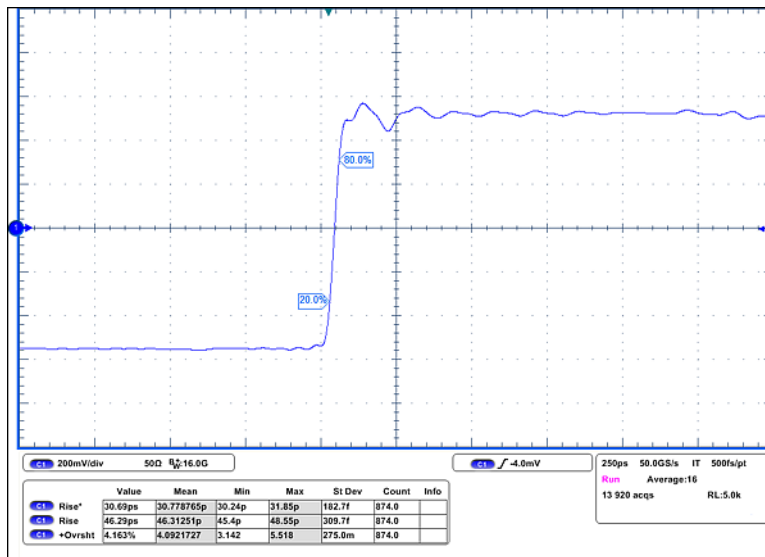

Figure 19: P75PDPM with short ground spring, 0.180 in. spacing

Input Impedance and Probe Loading

When you connect the probe inputs to a circuit, you are introducing a new resistance, capacitance, and inductance into the circuit. Each input of the differential probe has a DC input impedance of 50 k Ω to ground. (See Figure 20.)

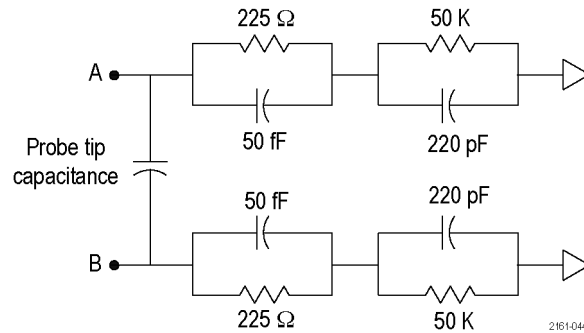

Figure 20: TriMode probe input model

For signals with low source impedance and frequency, the 50 k Ω input impedance on each input is large enough to prevent the inputs from loading the signal sources. The more the signal source impedance on an input increases, the more the probe loads the source and reduces the signal amplitude. The greater the source impedances and the higher the signal frequencies, the more you must take these factors into account.

The frequency of the signal also affects signal measurement. As the frequency of the signal increases, the input impedance of the probe decreases. The lower the impedance of the probe relative to that of the source, the more the probe loads the circuit under test and reduces the signal amplitude. A high frequency input impedance model is shown below. (See Figure 21.)

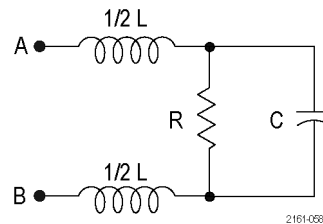
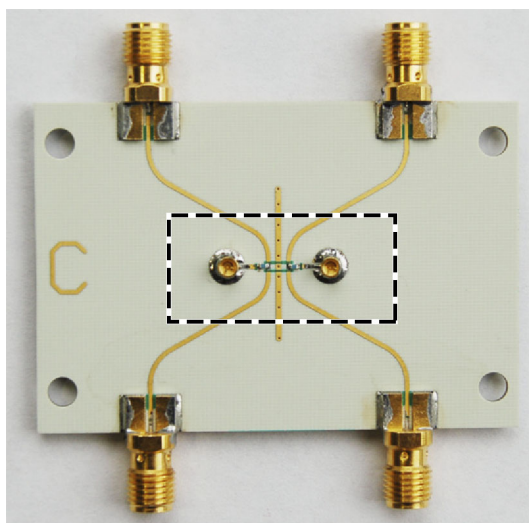

Figure 21: TriMode probe high frequency input impedance model

For plots and representative R-L-C values of the individual TriMode solder tips, refer to the specifications. (See page 27, *Tip Specifications*.)

Embedded Probe

It is possible to acquire signals with the P7500 Series TriMode probes by including an embedded connection in your circuit. (See Figure 22.) Connectors that mate to the P75TC Tip Cable can be incorporated in the circuit board design and carefully placed to balance any reflections or other characteristics that may affect the circuit or measurement. An embedded probe connection will generally provide optimum probe performance because the signal interconnect lead length can be minimized if implemented correctly. For more information about embedded probe connections, contact Tektronix.



2161403

Figure 22: Embedded probe fixture

Reference

This section contains information about taking measurements with the TriMode probes and increasing measurement accuracy.

Single-Ended Measurements Using A and B Modes

A differential probe such as the P7516 TriMode Probe can be used for single-ended measurements within the limits of its dynamic and offset voltage ranges.

Single-ended probes such as the P7240 typically have a wider offset range than differential probes, but with much lower bandwidth performance. (See Table 1.)

Table 1: Offset ranges

Probe	DC Offset, 5X	Dynamic Range, 5X	DC Offset, 12.5X	Dynamic Range, 12.5X
P7240	+/- 5 V	4 V _{PP}	–	–
P7513 & P7516 (differential mode)	+2.5 V, -1.5 V	1.5 V _{PP}	+2.5 V, -1.5 V	3.5 V _{PP}
P7513 & P7516 (single-ended and common-mode)	+3.4 V, -1.8 V	1.5 V _{PP}	+3.4 V, -1.8 V	3.5 V _{PP}
P7520 (differential mode)	+2.5 V, -1.5 V	1.25 V _{PP}	+2.5 V, -1.5 V	3.2 V _{PP}
P7520 (single-ended and common-mode)	+3.4 V, -1.8 V	1.25 V _{PP}	+3.4 V, -1.8 V	3.2 V _{PP}

Differential probes are ideal for a class of single-ended measurements where the reference voltage is not ground:

- SSTL_1,2: $V_{TT}, V_{REF} = V_{DD}/2$
- PECL: $V_{REF} = V_{CC}-1.3$

To measure single-ended signals in this class, connect the B input of the P7500 TriMode Probe to V_{REF} .

A differential probe in these applications displays the true signal despite any AC or DC variation in V_{REF} from its nominal value. A single-ended probe displays the signal plus the variation in V_{REF} .

Differential probes can also be used to make ground referenced single-ended measurements on either single-ended signals or differential signals like PCI Express or Serial ATA. To measure ground referenced single-ended signals with the handheld module, connect the B input of the P7500 TriMode Probe to ground.

Single-ended measurements on differential signals are used to measure common mode voltage and check for differential signal symmetry. By using the TriMode solder tip, you can easily take these measurements with one connection. Cycle the Input Mode switch to display the signal that you want to view.

Channel Isolation

Under ideal conditions when taking single-ended measurements with a differential probe, no part of a signal applied to one input of the probe would appear on the other input. In reality some portion of the signal on one input does “bleed” over to the other input, and this effect increases with frequency. Channel isolation is a measure of how much crosstalk occurs between the two probe inputs. The channel isolation is defined with S-parameter measurements below, where:

A input = S1, B input = S2, Output = S3

A ISOLATION = $20 \log (S32 / S31) | \text{A Mode}$

B ISOLATION = $20 \log (S31 / S32) | \text{B Mode}$

A typical isolation plot for the P7500 series TriMode probes using an embedded probe with zero-ground lead length is shown. Channel isolation performance is highly dependent on probe tip attachment lead length. Good channel isolation requires keeping the interconnect lead length for both signal and ground connections very short. (See Figure 23.)

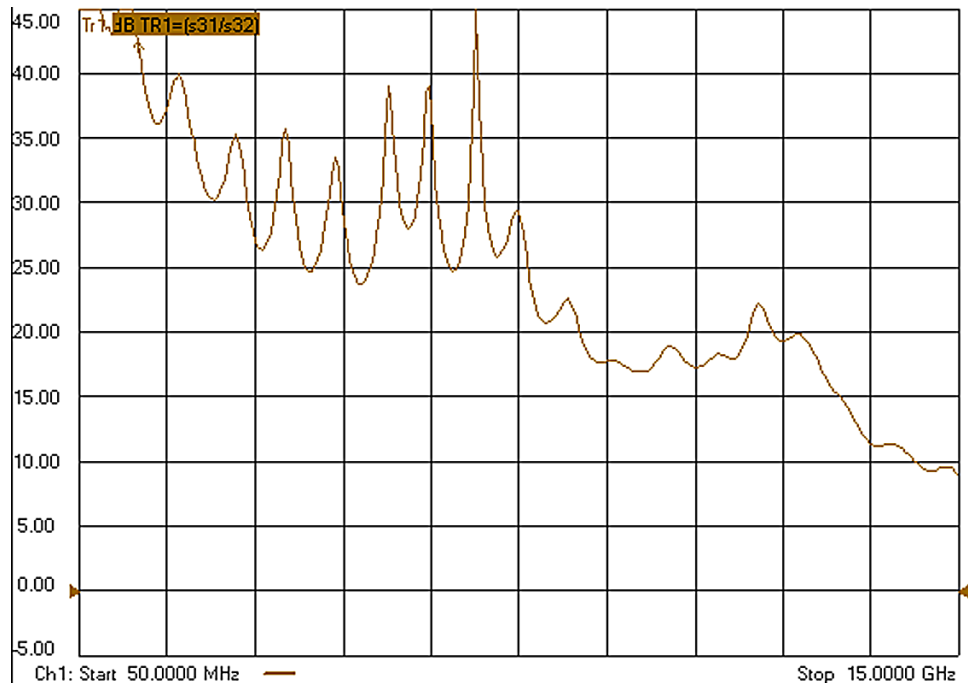

Figure 23: Typical channel isolation for P7500 Series TriMode probes

Differential Measurements

A differential probe is optimized to measure high speed differential signals. Differential signals are formed from two complementary signals with a common reference voltage. (See Figure 24.)

Devices designed for differential measurements avoid problems presented by single-ended systems. These devices include a variety of differential probes, differential amplifiers, and isolators.

A differential probe is basically a differential amplifier, which is used to make differential measurements that reject any voltage that is common to the inputs and amplifies any difference between the inputs. Voltage that is common to both inputs is often referred to as the Common-Mode Voltage (V_{CM}) and voltage that is different as the Differential-Mode Voltage (V_{DM}).

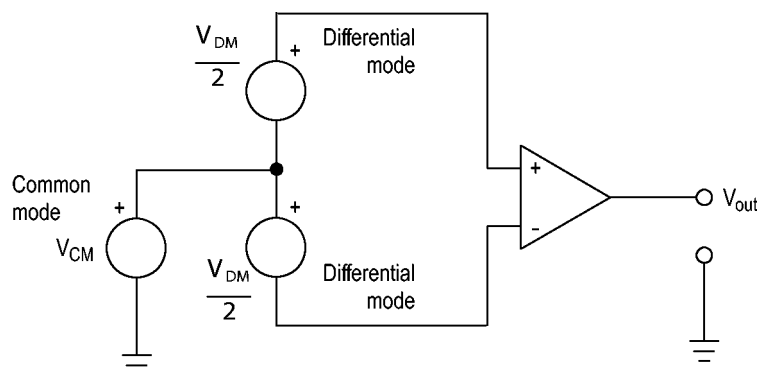

Figure 24: Simplified model of a differential amplifier

Common-Mode Rejection Ratio

Differential amplifiers cannot reject all of the common-mode signal. The ability of a differential amplifier to reject the common-mode signal is expressed as the Common-Mode Rejection Ratio (CMRR). The CMRR is the differential-mode gain (A_{DM}) divided by the common-mode gain (A_{CM}). It is expressed either as a ratio or in dB.

$$CMRR = \frac{A_{DM}}{A_{CM}} \quad dB = 20 \log \frac{A_{DM}}{A_{CM}}$$

CMRR generally is highest (best) at DC and degrades with increasing frequency. A typical CMRR plot for the P7500 Series TriMode probes is shown. (See Figure 25 on page 20.)

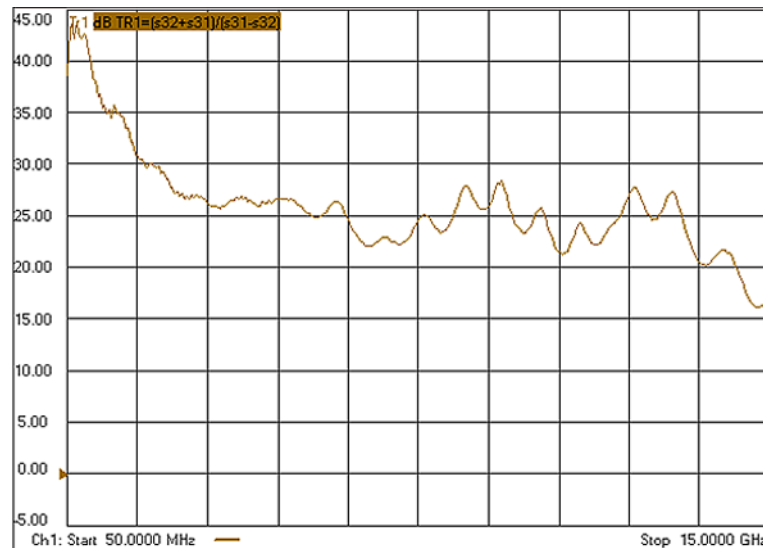

Figure 25: Typical CMRR for P7500 Series TriMode probes

Assessing CMRR Error

The CMRR of the P7500 Series TriMode Probes is shown in graphs assuming a sinusoidal common-mode signal.

A quick way to assess the magnitude of CMRR error when the common-mode signal is not sinusoidal is to connect both leads to the same point in the circuit. The oscilloscope displays only the common-mode component that is not fully rejected by the probe. While this technique may not give you accurate measurements, it does allow you to determine if the magnitude of the common-mode error signal is significant. Make the probe tip wires the same length to maximize the probe CMRR.

Input Impedance Effects on CMRR

The lower the input impedance of the probe relative to the source impedance, the lower the CMRR for a given source impedance imbalance. Differences in the source impedance driving the two inputs lowers the CMRR. Note that single-ended measurements generally result in asymmetric source impedances which tend to reduce the differential mode CMRR.

Differential-Mode Rejection

When making common-mode signal measurements ($A+B/2 -GND$) with the TriMode probe, it is desirable to reject the differential-mode signal present between the two inputs. This rejection is expressed as the Differential-Mode Rejection Ratio (DMRR), and is defined as the common-mode gain (A_{CM}) divided by the differential-mode gain (A_{DM}). It is expressed either as a ratio or in dB, and degrades at higher frequencies.

$$DMRR = \frac{A_{CM}}{A_{DM}} \quad dB = 20 \log \frac{A_{CM}}{A_{DM}}$$

Serial Bus Standards

The table below lists some popular high-speed data communication standards that can be measured with the P7500 Series TriMode Probes.

Table 2: Serial bus standards with dynamic range requirements

Standard Data Rate	Vdm_max	Vdm_min	Vcm_max	Vcm_min
HDMI/DVI 1.65 Gb/s	800 mV	150 mV	3.3 V	2.8 V
InfiniBand TX 2.5 Gb/s	1.6 V	1.0 V	1.0 V	0.5 V
InfiniBand RX 2.5 Gb/s	1.6 V	0.175 V	1.0 V	0.5 V
PCI Express TX 2.5 Gb/s	1.2 V	0.8 V	AC	AC
PCI Express RX 2.5 Gb/s	1.2 V	0.175 V	AC	AC
Serial ATA TX 1.5 Gb/s	0.6 V	0.4 V	0.3 V	0.2 V
Serial ATA RX 1.5 Gb/s	0.6 V	0.325 V	0.3 V	0.2 V
XAUI TX 3.125 Gb/s		0.4 V		
XAUI RX 3.125 Gb/s		0.1 V		
OIF-Sxl-5 TX 3.125 Gb/s	1.0 V	0.5 V	1.23 V	0.72 V
OIF-Sxl-5 RX 3.125 Gb/s	1.0 V	0.175 V	1.30 V	1.10 V
LV PECL (std ECL) >12 GHz	1.66 V (typ)	1.48 V	1.3 V (vt)	0.5 V (vt)
LV PECL (RSECL) >12 GHz	1.05 V	0.70 V	1.3 V (vt)	0.5 V (vt)

Specifications

These specifications apply to the P7500 Series TriMode Probes installed on an oscilloscope with a TekConnect interface. When the probe is used with another oscilloscope, the oscilloscope must have an input impedance of 50 Ω . The probe must have a warm-up period of at least 20 minutes and be in an environment that does not exceed the allowed limits. (See Table 3.)

Specifications for the P7500 Series TriMode Probes fall into three categories: warranted, typical, and nominal characteristics.

Warranted Characteristics

Warranted characteristics describe guaranteed performance within tolerance limits or certain type-tested requirements.

Table 3: Warranted electrical characteristics

Characteristic	Specification (applies to all models unless specified otherwise.)			
		P7513	P7516	P7520
Rise time ¹	10–90%	<40 ps	<32 ps	<27 ps (differential) <29 ps (A, B, CM)
	20–80%	<28 ps	<24 ps	<18 ps (differential) <20 ps (A, B, CM)
DC attenuation accuracy		0.200 \pm 2% (5X)		
		0.0800 \pm 2% (12.5X)		
Output Offset Zero		\pm 3 mV (+20 to +30 °C, +68 to +86 °F) (5X) \pm 15 mV on oscilloscope		
		\pm 3 mV (+20 to +30 °C, +68 to +86 °F) (12.5X) \pm 37.5 mV on oscilloscope		
Temperature		Operating: 0 to +40 °C (+32 to +104 °F),		
		Nonoperating: –20 to +71 °C (-4 to +160 °F)		
Humidity		Operating: 20–80% RH, at up to +40 °C (+104 °F)		
		Nonoperating: 5–90% RH		
Altitude		Operating: 3000 meters (10,000 feet)		
		Nonoperating: 12,000 meters (40,000 feet)		

¹ Measurements taken using an embedded probe fixture and a 250 mV step (18 to 28 °C +64 to +82 °F)

Typical Characteristics

Typical characteristics describe typical but not guaranteed performance.

Table 4: Typical electrical characteristics

Characteristic		Specification (applies to all models unless specified otherwise)		
		P7513	P7516	P7520
Bandwidth ¹		>13 GHz	>16 GHz	>20 GHz (differential) >18 GHz (A, B, CM)
Operating Voltage Window		-2.0 V to +4.0 V	-2.0 V to +4.0 V	-2.0 V to +3.7 V
Differential signal range (DC coupled)	5X	±0.750 V	±0.750 V	±0.625 V
	12.5X	±1.75 V	±1.75 V	±1.60 V
Linearity	5X	±1% over a dynamic range of -0.75 V to +0.75 V		±1% over a dynamic range of -0.625 V to +0.625 V
	12.5X	±1% over a dynamic range of -1.75 V to +1.75 V		±1% over a dynamic range of -1.60 V to +1.60 V
Offset voltage range	Differential	-1.5 V to +2.5 V		
	Single-ended and common-mode	-1.8 V to +3.4 V		
Offset scale accuracy (referred to input)	Differential	0.093 ±2%		
	Single-ended and common-mode	0.186 ±2%		
DC offset drift (referred to input)	Differential	-0.47 mV/ °C (5X)		-0.100 μV/ °C (5X)
		-0.72 mV/ °C (12.5X)		-0.60 μV/ °C (12.5X)
DC voltage measurement accuracy	5X	±(2% of input + 2% of offset + 15 mV + 6.25 mV)		±(2% of input + 2% of offset + 15 mV + 6.25 mV)
		12.5X	±(2% of input + 2% of offset + 37.5 mV + 16 mV)	
Maximum nondestructive input voltage			±15 V _(DC + peak AC) between each input or between either probe inputs and ground	
Input impedance		(See page 27, <i>Tip Specifications</i> .)		
Differential input resistance, DC coupled		100 kΩ ±6 kΩ		
Input resistance matching		±250 Ω side-to-side with respect to ground		
Common-mode input resistance, DC coupled		50 kΩ ±3 kΩ		
Common-mode rejection ratio, differential-mode ¹		>60 dB at DC	>60 dB at DC	>60 dB at DC
		>40 dB to 50 MHz	>40 dB to 50 MHz	>40 dB to 50 MHz
		>30 dB to 1 GHz	>30 dB to 1 GHz	>30 dB to 1 GHz
		>20 dB to 7 GHz	>20 dB to 8 GHz	>20 dB to 10 GHz
		>15 dB to 13 GHz	>15 dB to 16 GHz	>12 dB to 20 GHz

Specifications

Characteristic	Specification (applies to all models unless specified otherwise)		
	P7513	P7516	P7520
Differential-mode rejection ratio, common-mode ¹	>40 dB to 50 MHz	>40 dB to 50 MHz	>40 dB to 50 MHz
	>30 dB to 1 GHz	>30 dB to 1 GHz	>30 dB to 1 GHz
	>20 dB to 7 GHz	>20 dB to 8 GHz	>20 dB to 9 GHz
	>15 dB to 13 GHz	>15 dB to 16 GHz	>12 dB to 18 GHz
Channel isolation, single-ended mode ¹	>40 dB to 50 MHz	>40 dB to 50 MHz	>40 dB to 50 MHz
	>30 dB to 1 GHz	>30 dB to 1 GHz	>30 dB to 1 GHz
	>20 dB to 7 GHz	>15 dB to 8 GHz	>15 dB to 9 GHz
	>10 dB to 13 GHz	>4 dB to 16 GHz	>6 dB to 18 GHz
Noise	Differential	<33 nV/ \sqrt{Hz} (5X)	
		<48 nV/ \sqrt{Hz} (12.5X)	
	Single-ended and common-mode	<38 nV/ \sqrt{Hz} (5X)	<33 nV/ \sqrt{Hz} (5X)
		<52 nV/ \sqrt{Hz} (12.5X)	<48 nV/ \sqrt{Hz} (12.5X)
Delay time	4.4 ns \pm 0.1 ns		

¹ Embedded probe only. Refer to *Tip Specifications* for specifications when using TriMode accessory tips. (See page 27, *Tip Specifications*.)

Table 5: Typical mechanical characteristics

Characteristic	Description
Dimensions, control box	125.4 mm × 41 mm × 35 mm (4.9 in × 1.6 in × 1.4 in)
Dimensions, probe body	101.6 mm × 8.89 mm × 19 mm (4.0 in × 0.350 in × 0.750 in)
Dimensions, cable length	1.0 m (39.3 in) (from the probe body to the control box)
Unit weight	1.550 g (3.1 lbs) (probe, accessories and packaging)

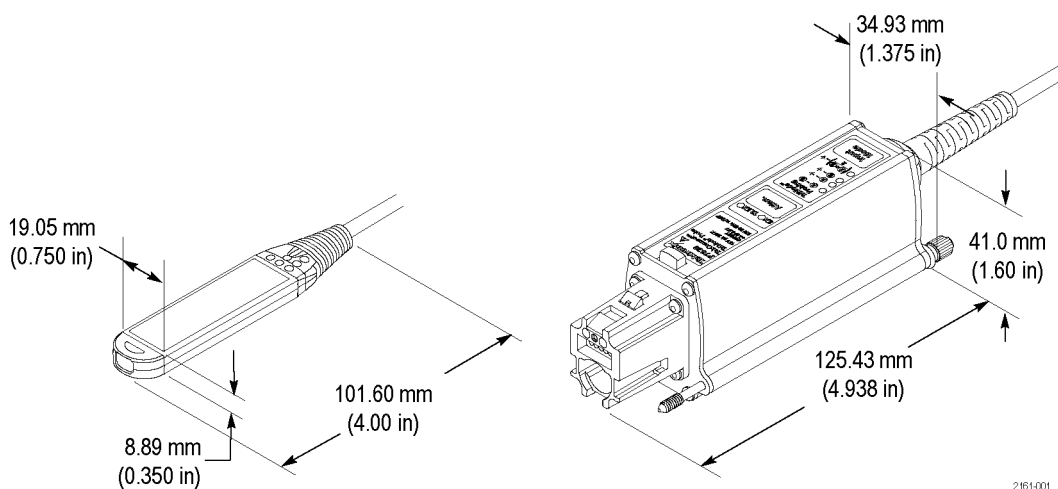

Figure 26: Probe body and control box dimensions

Nominal Characteristics

Nominal characteristics describe guaranteed traits, but the traits do not have tolerance limits.

Table 6: Nominal electrical characteristics

Characteristic		Description
Input configuration	P75TLRST solder tip	Differential (two signal inputs, A and B; shared with single-ended) Single-ended (one each A and B signal input and two ground inputs)
	TriMode Resistor & Extended Resistor solder tips	Differential (two signal inputs, A and B; shared with single-ended) Single-ended (one each A and B signal input and two ground inputs)
	P75PDPM handheld module	Differential (two inputs, A and B)
Output coupling		DC
Probe attenuation settings		5X and 12.5X

Tip Specifications

This section lists specifications that are applicable to the probe when used with the accessory tips available for the TriMode probes.

P75TLRST TriMode Long Reach Solder Tip

Specifications are typical and apply to all ranges and input modes unless specified otherwise.

Probe model (bandwidth)	Rise time	CMRR	DMRR	Channel Isolation
P7513 (>13.0 GHz)	10%–90%: <40 ps 20%–80%: <32 ps	>60 dB at DC >40 dB at 50 MHz >30 dB at 1 GHz >20 dB at 7 GHz >15 dB at 13 GHz	>40 dB at 50 MHz >30 dB at 1 GHz >20 dB at 7 GHz >15 dB at 13 GHz	>40 dB at 50 MHz >30 dB at 1 GHz >20 dB at 7 GHz >10 dB at 13 GHz
P7516 (>16.0 GHz)	10%–90%: <28 ps 20%–80%: <24 ps	>60 dB at DC >40 dB at 50 MHz >30 dB at 1 GHz >20 dB at 8 GHz >15 dB at 16 GHz	>40 dB at 50 MHz >30 dB at 1 GHz >20 dB at 8 GHz >15 dB at 16 GHz	>40 dB at 50 MHz >30 dB at 1 GHz >20 dB at 8 GHz >6 dB at 16 GHz
P7520 (>20 GHz Diff mode) (>18 GHz A, B, CM)	10%–90%: <27 ps (Diff mode) <29 ps (A, B, CM modes) 20%–80%: <18 ps (Diff mode) <20 ps (A, B, CM modes)	>60 dB at DC >40 dB at 50 MHz >30 dB at 1 GHz >20 dB at 10 GHz >15 dB at 20 GHz	>40 dB at 50 MHz >30 dB at 1 GHz >20 dB at 9 GHz >15 dB at 18 GHz	>40 dB at 50 MHz >30 dB at 1 GHz >15 dB at 9 GHz >6 dB at 18 GHz

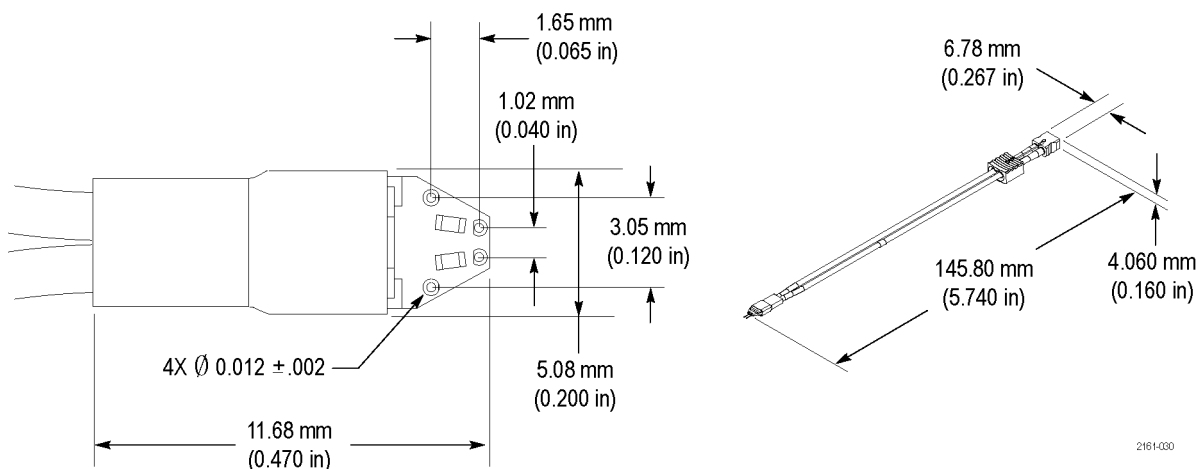

Figure 27: P75TLRST TriMode Long Reach Solder Tip dimensions

The following figure shows the typical step response of the TriMode probes with the P75TLRST solder tip. A 50 ps rise time pulse source was used for this measurement.

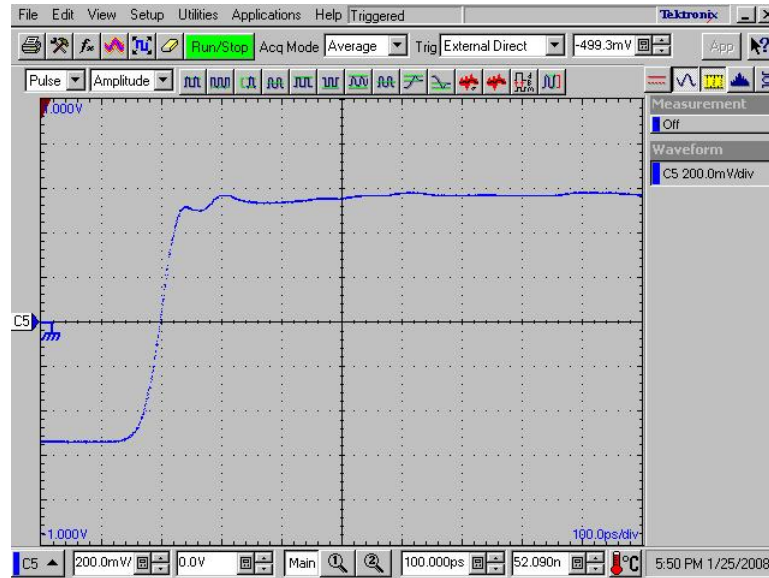

Figure 28: TriMode probe with the P75TLRST solder tip

The following figure shows a typical impedance plot of the TriMode probes with the P75TLRST solder tip.

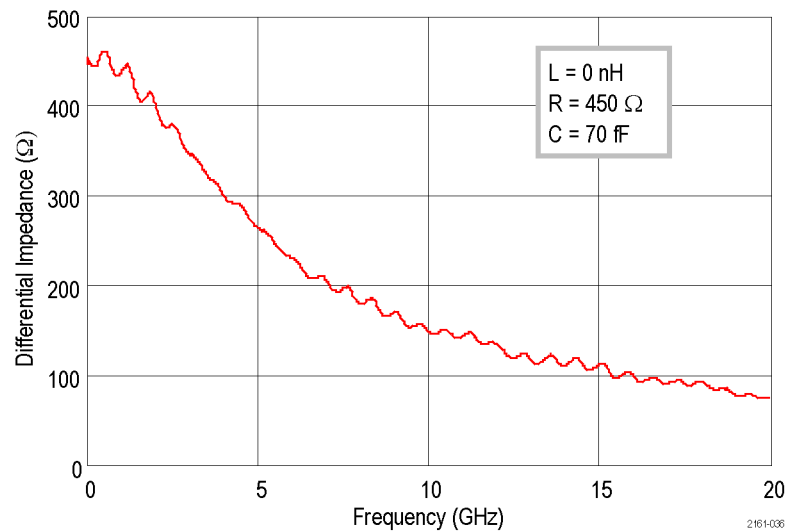

Figure 29: P75TLRST differential impedance

TriMode Resistor Solder Tip

Specifications are typical and apply to all ranges and input modes unless specified otherwise.

Probe model (bandwidth)	Rise time	CMRR	DMRR	Channel Isolation
P7513 (>13.0 GHz Diff mode) (>12.0 GHz A, B modes) (>5.0 GHz CM mode)	10%–90%: <40 ps 20%–80%: <28 ps	>60 dB at DC >40 dB at 50 MHz >30 dB at 1 GHz >20 dB at 7 GHz >15 dB at 13 GHz	>40 dB at 50 MHz >30 dB at 1 GHz >20 dB at 7 GHz >15 dB at 13 GHz	>40 dB at 50 MHz >30 dB at 1 GHz >15 dB at 7 GHz >10 dB at 13 GHz
P7516 (>16.0 GHz Diff mode) (>15.0 GHz A, B modes) (>12.0 GHz CM mode)	10%–90%: <32 ps Diff mode <34 ps A, B modes <36 ps CM mode 20%–80%: <24 ps Diff mode <24 ps A, B modes <26 ps CM mode	>60 dB at DC >40 dB at 50 MHz >30 dB at 1 GHz >20 dB at 8 GHz >15 dB at 16 GHz	>40 dB at 50 MHz >30 dB at 1 GHz >20 dB at 8 GHz >15 dB at 16 GHz	>40 dB at 50 MHz >30 dB at 1 GHz >15 dB at 8 GHz >10 dB at 16 GHz
P7520 (>18.0 GHz Diff mode) (>15.0 GHz A, B modes) (>12.0 GHz CM mode)	10%–90%: <29 ps Diff mode <32 ps A, B modes <34 ps CM mode 20%–80%: <20 ps Diff mode <22 ps A, B modes <24 ps CM mode	>60 dB at DC >40 dB at 50 MHz >30 dB at 1 GHz >20 dB at 10 GHz >15 dB at 20 GHz	>40 dB at 50 MHz >30 dB at 1 GHz >20 dB at 9 GHz >15 dB at 18 GHz	>40 dB at 50 MHz >30 dB at 1 GHz >15 dB at 9 GHz >10 dB at 18 GHz

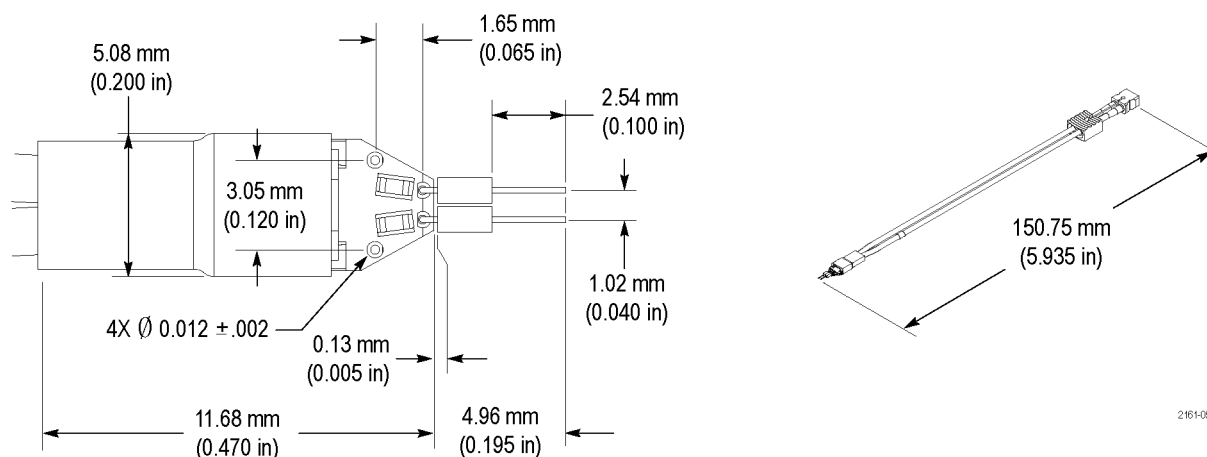

Figure 30: TriMode Resistor solder tip dimensions

The following figure shows the typical step response of the TriMode probes with the TriMode resistor solder tip. A 50 ps rise time pulse source was used for this measurement.

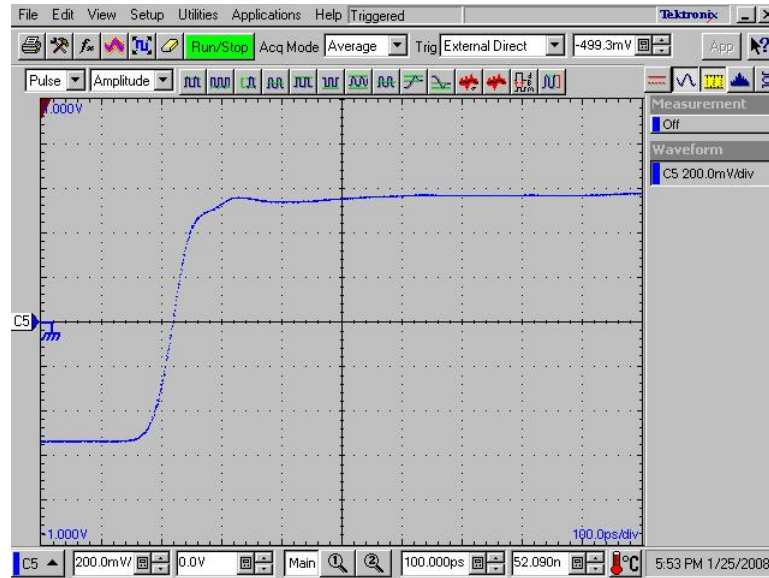

Figure 31: Step response with the TriMode Resistor solder tip

The following figure shows a typical impedance plot of the TriMode probes with the TriMode resistor solder tip.

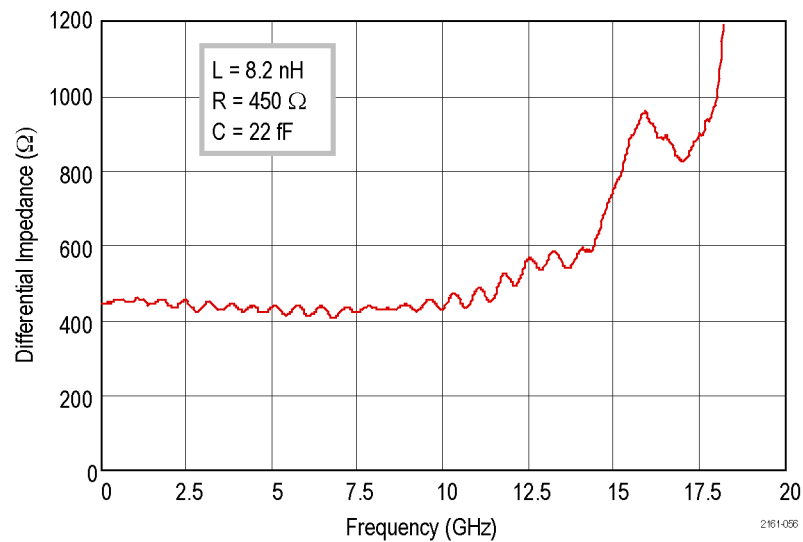

Figure 32: TriMode Resistor solder tip differential impedance

TriMode Extended Resistor Solder Tip

Specifications are typical and apply to all ranges and input modes unless specified otherwise.

Probe model (bandwidth)	Rise time	CMRR	DMRR	Channel Isolation
P7513 (>5.6 GHz Diff mode)	10%–90%: <40 ps Diff mode	>60 dB at DC >40 dB at 50 MHz >30 dB at 1 GHz	>40 dB at 50 MHz >30 dB at 1 GHz >20 dB at 7 GHz >15 dB at 13 GHz	>40 dB at 50 MHz >30 dB at 1 GHz >15 dB at 7 GHz >10 dB at 13 GHz
(>3.4 GHz A, B modes)	<110 ps A, B modes <120 ps CM mode	>30 dB at 1 GHz >20 dB at 7 GHz >15 dB at 13 GHz		
(>2.5 GHz CM mode)	20%–80%: <28 ps Diff mode <32 ps A, B modes <40 ps CM mode			
P7516 (>5.8 GHz Diff mode)	10%–90%: <36 ps Diff mode	>60 dB at DC >40 dB at 50 MHz >30 dB at 1 GHz	>40 dB at 50 MHz >30 dB at 1 GHz >20 dB at 8 GHz >15 dB at 16 GHz	>40 dB at 50 MHz >30 dB at 1 GHz >15 dB at 8 GHz >10 dB at 16 GHz
(>3.6 GHz A, B modes)	<100 ps A, B modes <120 ps CM mode	>30 dB at 1 GHz >20 dB at 8 GHz >15 dB at 16 GHz		
(>2.5 GHz CM mode)	20%–80%: <24 ps Diff mode <30 ps A, B modes <40 ps CM mode			
P7520 (>7 GHz Diff mode)	10%–90%: <32 ps Diff mode	>60 dB at DC >40 dB at 50 MHz >30 dB at 1 GHz	>40 dB at 50 MHz >30 dB at 1 GHz >20 dB at 9 GHz >15 dB at 18 GHz	>40 dB at 50 MHz >30 dB at 1 GHz >15 dB at 9 GHz >10 dB at 18 GHz
(>4 GHz A, B modes)	<50 ps A, B modes <120 ps CM mode	>30 dB at 1 GHz >20 dB at 10 GHz >15 dB at 20 GHz		
(>2.5 GHz CM mode)	20%–80%: <24 ps Diff mode <30 ps A, B modes <40 ps CM mode			

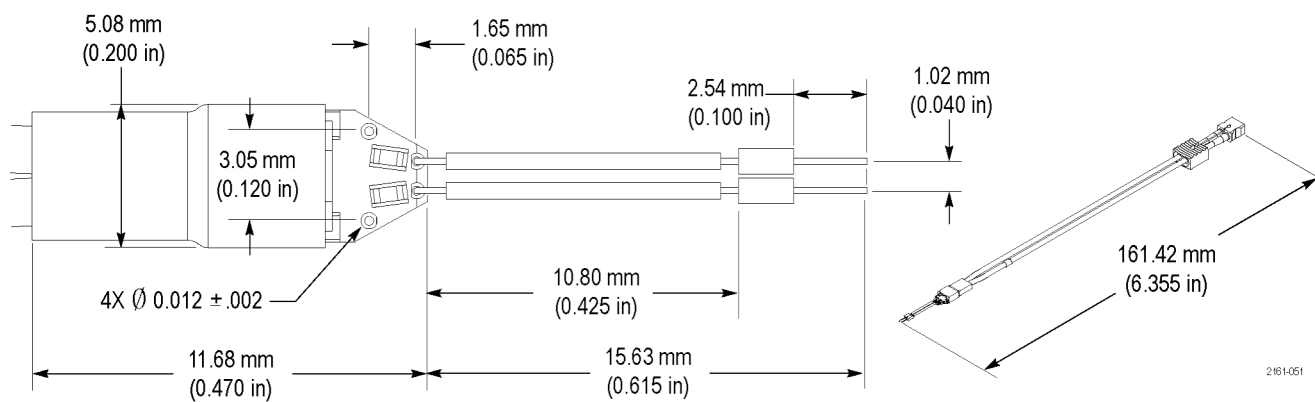

Figure 33: TriMode Extended Resistor solder tip dimensions

The following figure shows the typical step response of the TriMode probes with the TriMode extended resistor solder tip. A 50 ps rise time pulse source was used for this measurement.

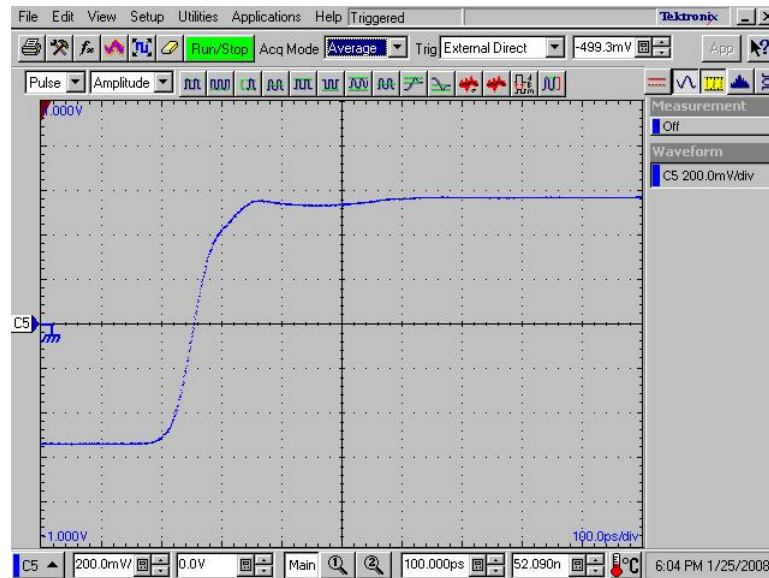

Figure 34: Step response with the TriMode Extended Resistor solder tip

The following figure shows a typical impedance plot of the TriMode probes with the TriMode extended resistor solder tip. The L=0 value gives a simplified model that follows the lower impedance limit envelope.

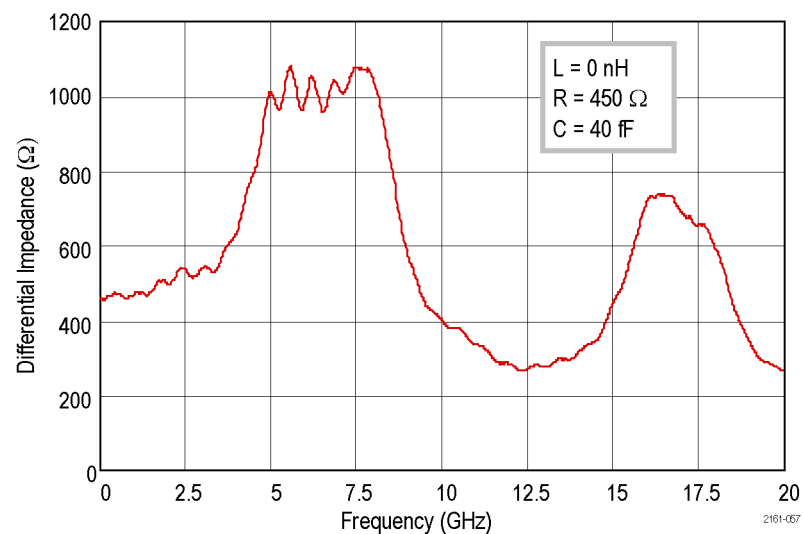

Figure 35: TriMode Extended Resistor solder tip differential impedance

P75PDPM Precision Differential Probing Module

Specifications are typical and apply to all ranges and input modes unless specified otherwise.

Probe model (bandwidth)	Rise time	CMRR
P7513 (>13.0 GHz)	10%–90%: <40 ps 20%–80%: <32 ps	>60 dB at DC >40 dB at 50 MHz >30 dB at 1 GHz >20 dB at 7 GHz >15 dB at 13 GHz
P7516 (>16.0 GHz)	10%–90%: <28 ps 20%–80%: <24 ps	>60 dB at DC >40 dB at 50 MHz >30 dB at 1 GHz >20 dB at 8 GHz >15 dB at 16 GHz
P7520 (>18.0 GHz)	10%–90%: <29 ps 20%–80%: <20 ps	>60 dB at DC >40 dB at 50 MHz >30 dB at 1 GHz >20 dB at 10 GHz >15 dB at 20 GHz

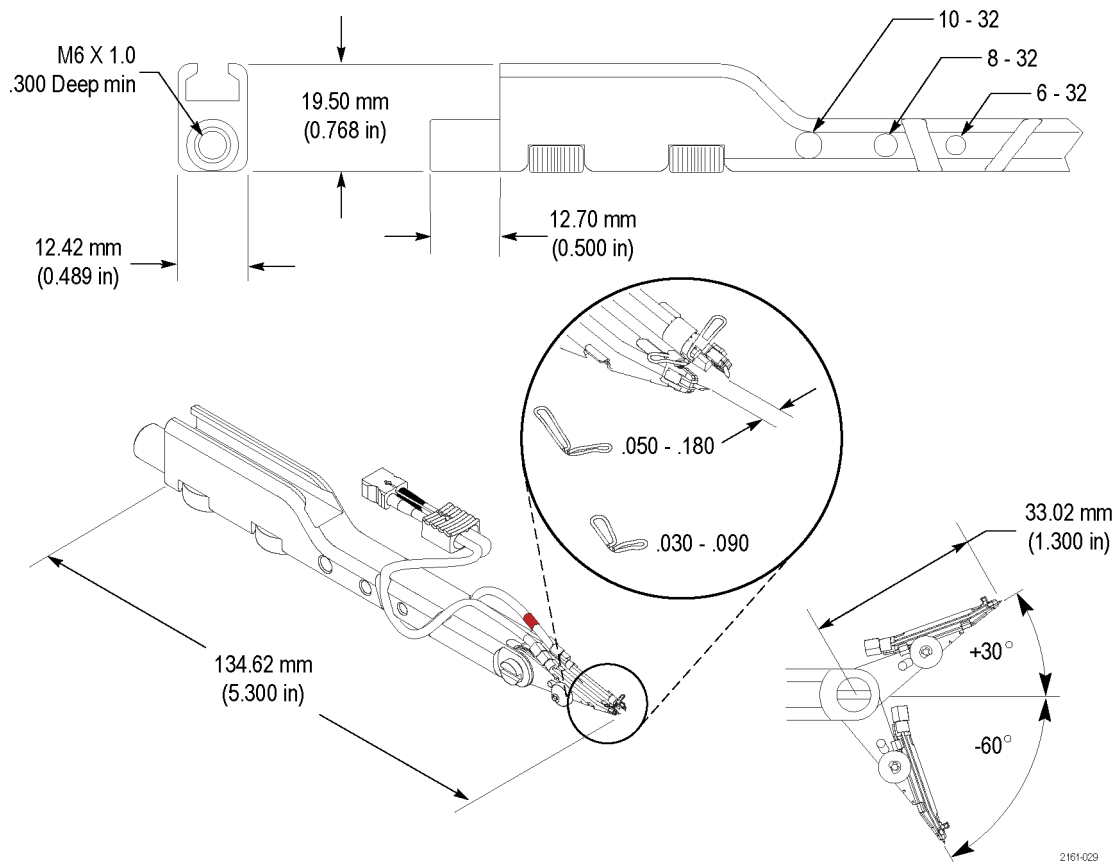

Figure 36: P75PDPM Precision Differential Probing Module dimensions

The following figure shows the typical step response of the TriMode probes with the P75PDPM probing module. A 50 ps rise time pulse source was used for this measurement.

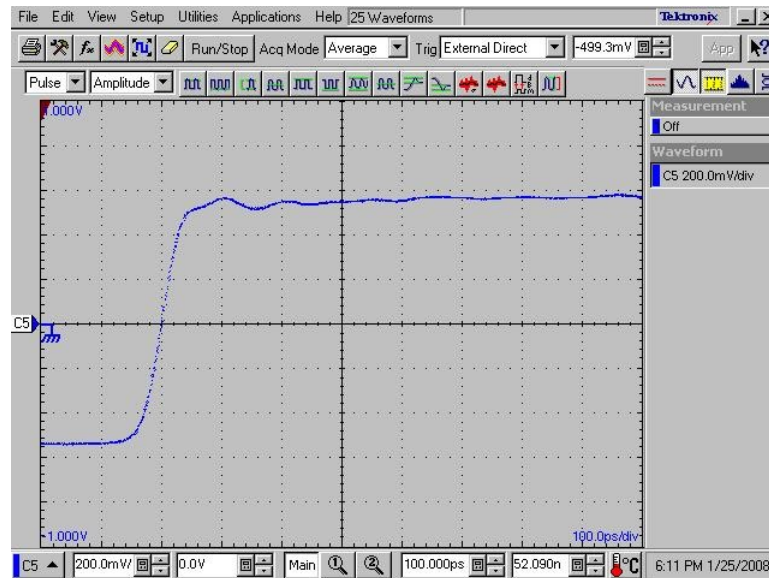

Figure 37: TriMode probe with the P75PDPM probing module

The following figure shows the typical differential impedance of the TriMode probes with the P75PDPM probing module.

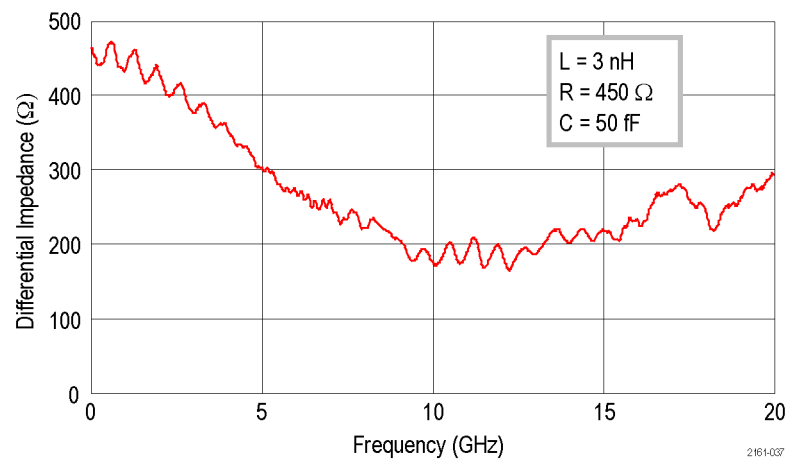

Figure 38: P75PDPM differential impedance

User Service

This section covers troubleshooting and probe maintenance.

If your probe does not meet the specifications listed in the *Specifications*, you can send the probe to Tektronix for repair. (See page 48, *Preparation for Shipment*.)

Error Condition

The LEDs on the probe alert you to error or status conditions affecting the probe. When the probe is functioning correctly, there is a quick flash of the LEDs on the probe just after connecting to the oscilloscope. If the probe LEDs flash or otherwise appear to be malfunctioning, an error condition may exist. Disconnect the probe and reconnect it to another channel to isolate the problem. If the symptoms persist with the probe, call your Tektronix representative for service.

Replaceable Parts

The following parts may need to be replaced due to normal wear and damage. When you replace these components, secure the probe in a small vise or positioner to simplify the procedure.

Table 7: TriMode probes replaceable parts

Description	Replacement part number
Probe body bullet contacts	013-0359-xx, kit of 4
P75TLRST solder tip wires	020-2754-xx, Wire Replacement Kit, includes one bobbin each: 4 mil wire, 8 mil wire, and SAC305 solder
TriMode Resistor (020-2936-xx) & TriMode Extended Resistor (020-2944-xx) solder tip resistors	020-2937-xx Replacement Resistor Kit, includes 50 each: 100 Ω leaded resistors, 75 Ω surface mount resistors, nonconductive tubing
P75PDPM Probing Module springs	016-1998-xx, kit of 4 (large springs) 016-1999-xx, kit of 4 (small springs)
P75PMT Probing Module tips (left and right)	P75PMT, one pair
P75TC Probing Module Tip Cable	P75TC, qty. 1

Refer to the user manual for a list of the accessories that are available for your probe.

Table 8: Required equipment

Description	Minimum requirement	Recommended example ¹
Connector separator tool	Custom tool	003-1897-xx
Ground spring tool	Custom tool	003-1900-xx
Tweezers	General purpose	
Magnifying glass or microscope	Free standing to allow hands-free use	
Probe positioner or bench vise	Able to hold probe	PPM203B or PPM100

¹ Nine-digit part numbers (xxx-xxxx-xx) are Tektronix part numbers.

Replacing probe body bullet contacts

The bullet contacts in the probe body should be replaced every 200 insertion cycles. Follow these steps to replace the bullets by using the removal tool:

Remove.

1. Squeeze the tool plunger to extend the holder tangs.
2. Insert the tool into the probe body so that the holder tangs surround one of the bullets.
3. Release the plunger to secure the holder tangs on the bullet.
4. Gently pull the tool outward to remove the bullet.
5. Repeat for the other bullet.



CAUTION. *If you cannot extract the bullets with the bullet removal tool, use fine needle-nosed pliers and a magnifying glass or microscope. Be careful not to damage the probe body with the pliers.*

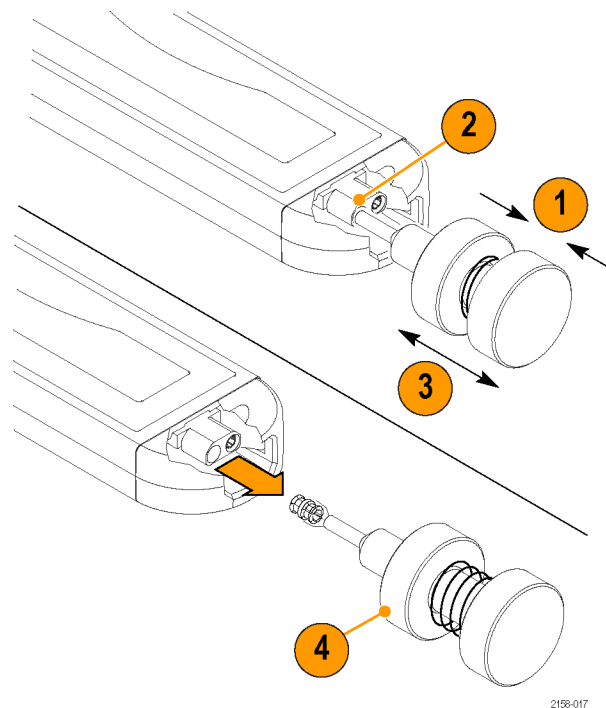

Figure 39: Removing the bullets

Install. When both bullets have been removed, install new bullets by doing the following:

1. Squeeze the tool plunger to extend the holder tangs.
2. Insert a new bullet into the tool so that the holder tangs surround the bullet.
3. Release the plunger to secure the holder tangs on the bullet.
4. Insert the tool into the probe body and seat the bullet in the recess.
5. Squeeze the tool plunger to release the bullet.
6. Gently pull the tool out of the probe body.
7. Repeat for the other bullet.
8. Test that the bullets are installed correctly by connecting and then removing an accessory solder tip to the probe head. Inspect the probe head and verify that the bullets remain seated in the probe head.

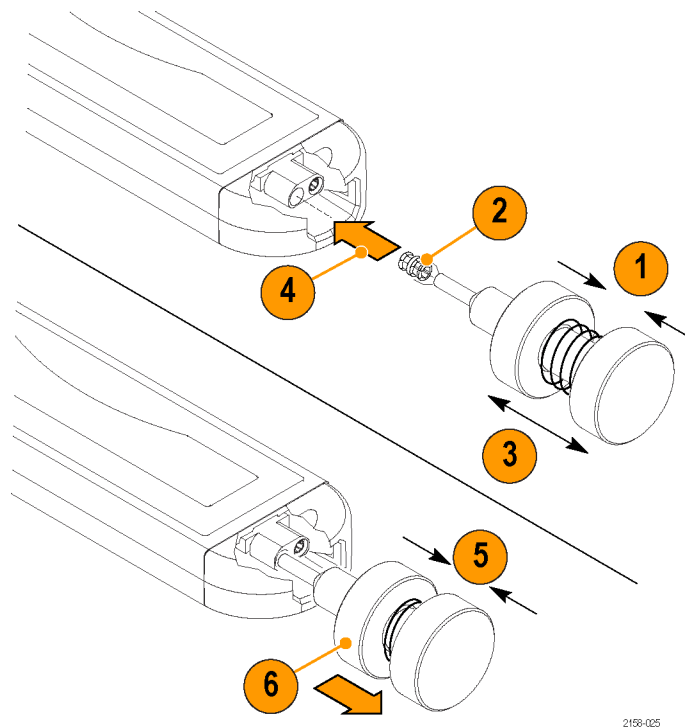

Figure 40: Installing the bullets

P75TLRST Solder Tip Wires

The solder vias on the circuit board at the end of the P75TLRST Solder Tip are small (0.012 in.), and require small wires to attach to your circuit. (Use the 4-mil and 8-mil wires included with the Wire Replacement kit to make the connections.) Because of the small dimensions, the solder tips have a limited number of solder cycles that the vias can withstand before the Solder Tips become unusable. If you expect to make frequent soldering changes, consider using the optional TriMode Resistor solder tips. The resistors that extend off of these tips can accept a higher number of solder cycles and can be replaced when necessary.

NOTE. *Axial-leaded tip resistors (included in the TriMode resistor replacement kit, Tektronix part number 020-2937-XX), should not be used in place of wires with the P75TLRST probe tip unless the surface-mount, SMD0402 resistors are also changed. The total probe tip resistance for the P7500 Series probes is designed to be 175 Ω .*



CAUTION. *To prevent damage to the circuit board or circuit board connections due to accidental movement of the probe and soldered leads, we recommend that you secure the tip to the circuit board using the adhesive tip tape provided in your accessory kit. You can also use other materials such as Kapton tape or hot glue.*

To avoid damage to the tip or the circuit under test, avoid applying excessive heat from the soldering iron. Use a low wattage, temperature-controlled soldering iron and appropriately sized soldering iron tip.

To prolong the life of your solder tips, consider the following points before you use the solder tips.

Consider the types of measurements that you plan to take. If you are going to take a few measurements at one location and then move to another, you may be able to use longer wires. Longer wires may degrade your measurement slightly (which may not matter), but the wires can then be cut or desoldered at your circuit and reused, rather than subjecting the solder tip to a desolder/solder cycle.

Perhaps the optional P75PDPM Precision Differential Probing Module is a better choice for the test points that you do not measure as often. The probing module can take both single-ended and differential measurements, and when used with a probe positioner, can provide hands-free access to tight spaces. Depending on your measurement requirements and circuit geometries, the probing module might be a preferable alternative.

At critical test points such as circuit outputs, you might need to keep the wires as short as possible. If possible, use the solder tip dimensions shown in the *Specifications* section to lay out a matching footprint on your circuit board.

Use the following precautions when you solder the tips:

- For best soldering results, use a microscope to examine the quality of the solder joints.
- Use a low-wattage, temperature-controlled soldering iron and a small mass soldering iron tip. The soldering iron temperature should be set as low as possible, while still providing a reliable solder joint.
- Use SAC305 solder (included with the wire replacement kit) to attach the tip wires to the circuit under test.
- When replacing tip wires or axial-lead resistors, solder wick can be used to remove the excess solder from the probe tip circuit board via holes. Be careful not to overheat the via and damage the board.
- The attachment wires should be bent symmetrically to vary the interconnect spacing. Use care when you solder a tip to a circuit under test to avoid inadvertently desoldering either the attachment wires or the damping resistor.
- For optimum performance and signal integrity, keep the lead length between the DUT (Device Under Test) and the tip as short as possible, and the lead lengths the same length.

P75PDPM Probing Module Springs

Equipment Required: ground spring tool, magnifying glass or microscope, tweezers, probe holder

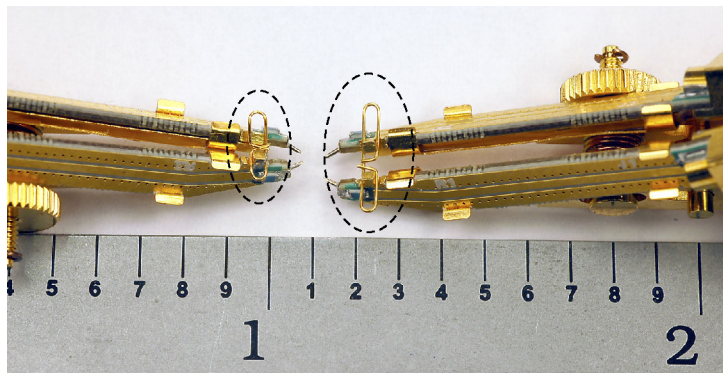
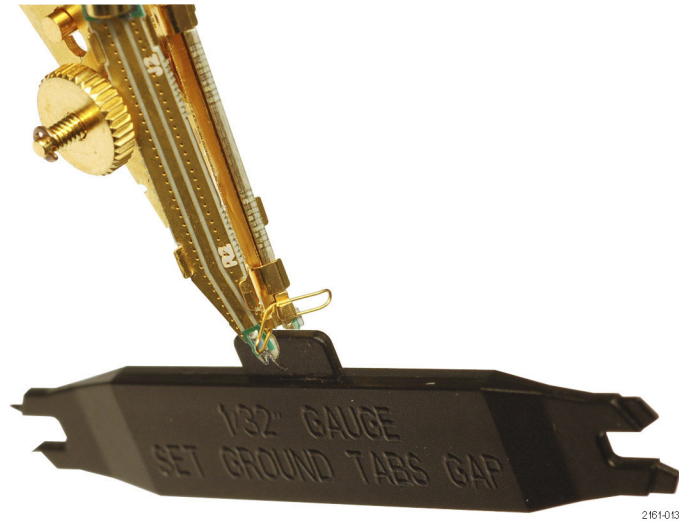

Figure 41: Large and small springs installed

Remove.

1. Adjust the tip gap using the gap measurement tab on the spring tool. Set the tool between the tip circuit boards, not the tips.

**Figure 42: Set the gap**

2. Insert the ground spring tool under the top of the spring.

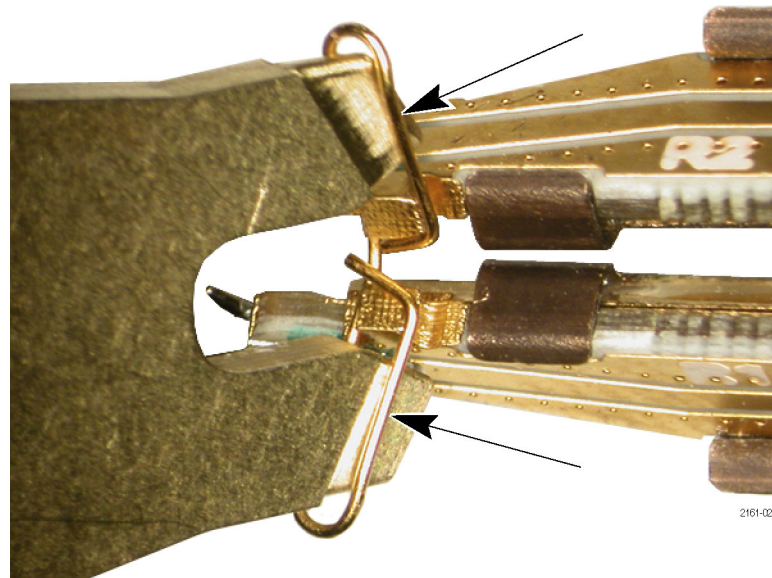
**Figure 43: Insert tool beneath spring**

3. Rock the tool away from the tips so that the spring clears the seat edge.

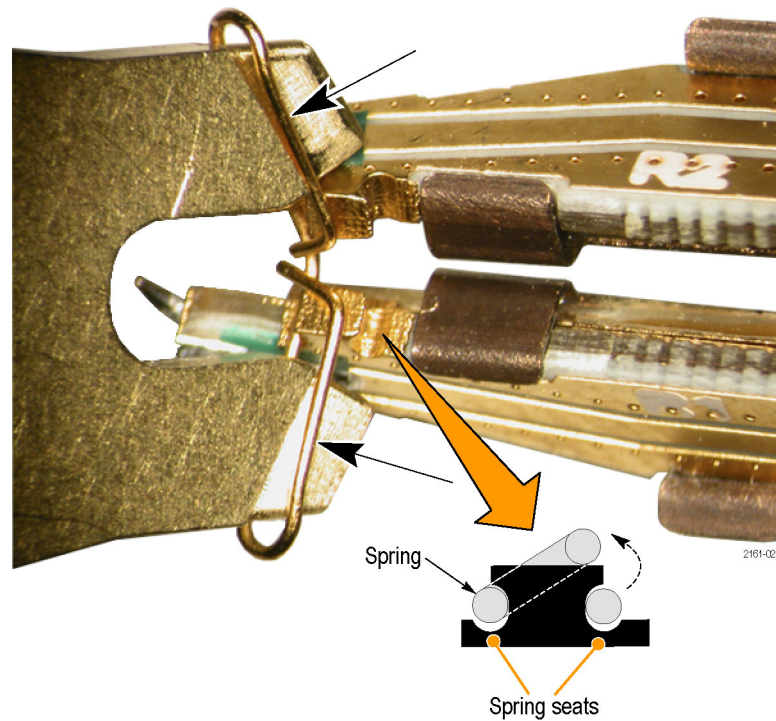
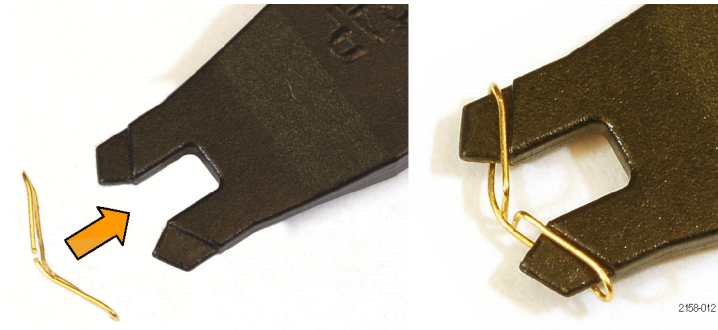

Figure 44: Transfer spring from tip to tool

4. Gently pull the tool away; the spring should come away with the tool.
5. Put the spring in the accessory container or a safe place to avoid losing the spring.

Install.

1. Two spring sizes are available: the small spring allows 0.030 – 0.090 in. (0.76 – 2.28 mm) tip span, the large spring allows 0.050 – 0.180 in. (1.27 – 4.57 mm) tip span.
2. Check that the tip gap is .032 in. using the gap measurement tab on the spring tool. Adjust if necessary.
3. Using tweezers, install the spring on the tool. The tool has a large and small side, one for each size spring. Make sure the gap in the spring is on the top of the tool as shown.

**Figure 45: Place spring on tool**

4. Set the bottom of the spring in the front seats (those closest to the tip ends). Maintain a slight pressure on the spring to keep it in the front seats.

**Figure 46: Set spring in front seat**

5. Set the top of the spring in the rear seats by lifting the tool to clear the edge of the rear seat with the top of the spring.

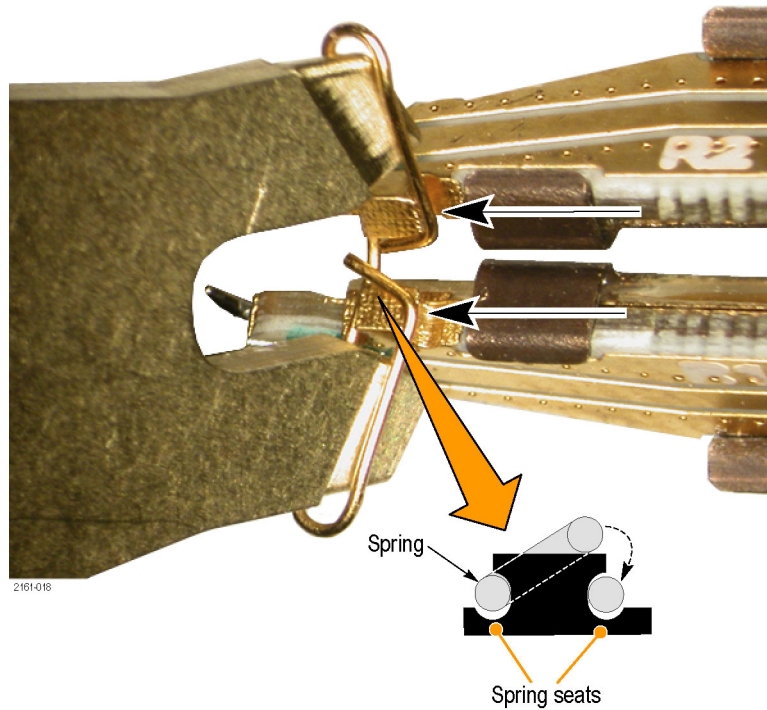

Figure 47: Set the spring in the rear seats

6. Gently retract the tool from the spring. Verify that the spring is seated as shown.

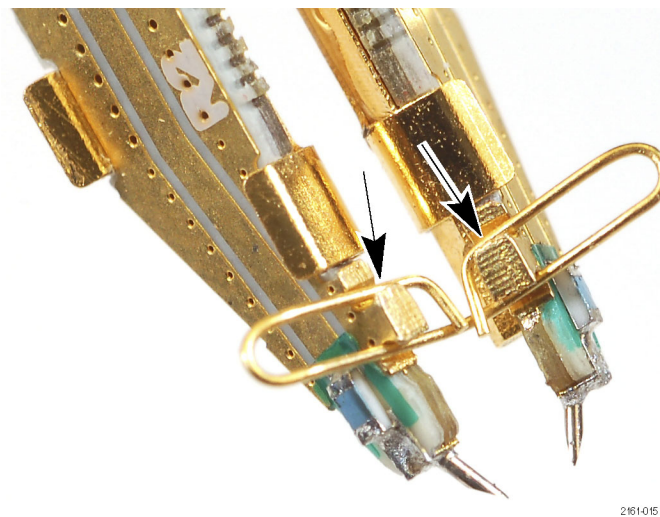

Figure 48: Properly seated spring

P75TC Probing Module Tip Cable

Equipment Required: connector separator tool

1. Disconnect the Cable Tip by the inserting the tool between the connectors. The tapered edges of the tool gently separate the cable connector from the tip connector.

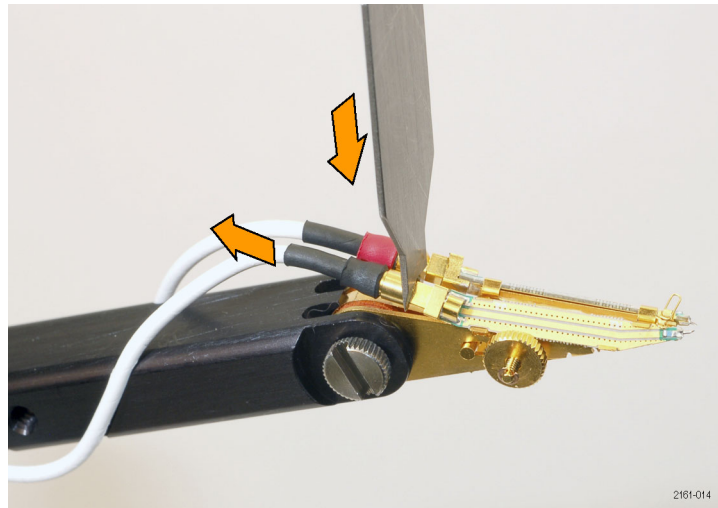

Figure 49: Disconnecting the tip cable

2. Repeat for the other cable and then pull both cables away from the tip connectors.

P75PMT Probing Module Tips (Left and Right)

Equipment Required: connector separator tool, magnifying glass or microscope (preferred), tweezers, and probe holder.

NOTE. *The probing module tips are electrically matched pairs and should be replaced together. Failure to do so may degrade the performance of your probe.*

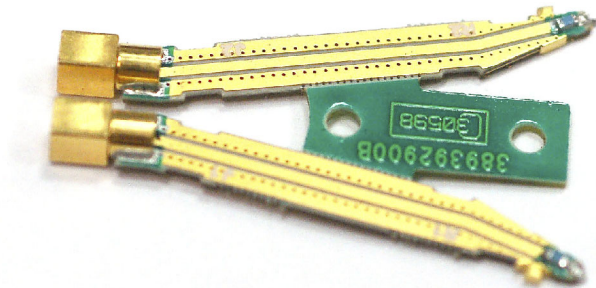

Figure 50: Probing module tips

Remove.

1. Disconnect the Cable Tips. (See page 45, *P75TC Probing Module Tip Cable*.)
2. Remove the spring. (See page 40, *P75PDPM Probing Module Springs*.)
3. Adjust the tip gap to maximum width.
4. Use the connector separator tool or a small screwdriver to pry the board up from the bottom. The bottom tabs are designed to flex; the top tabs are not.

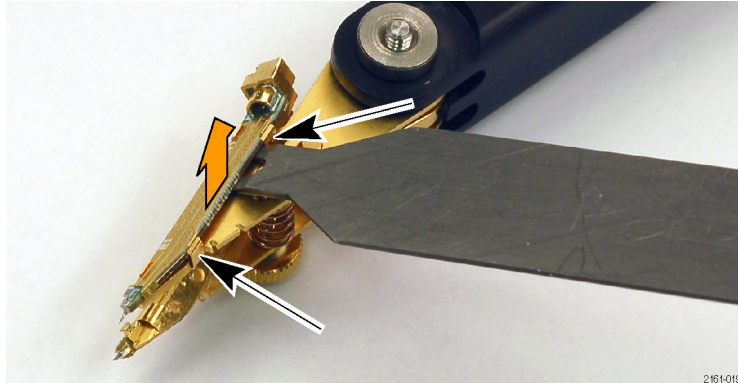

Figure 51: Removing the tip

5. Repeat for the other tip.

Install.

6. Separate the new tip board pair by snapping the board against a sharp edge.

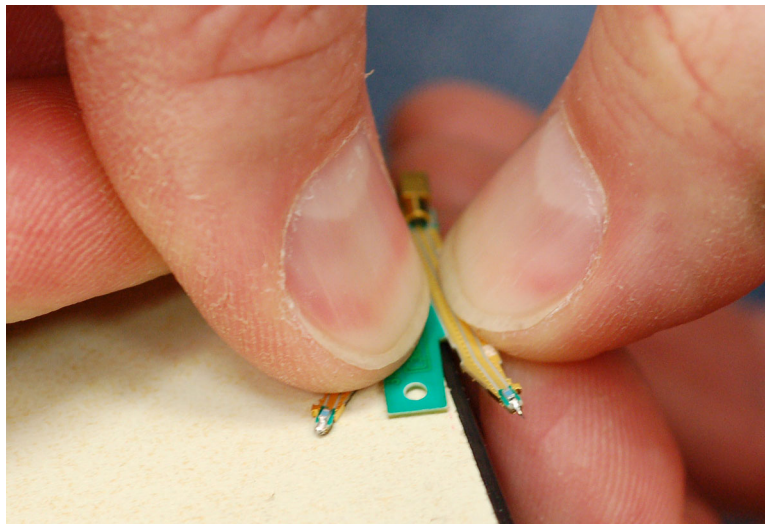
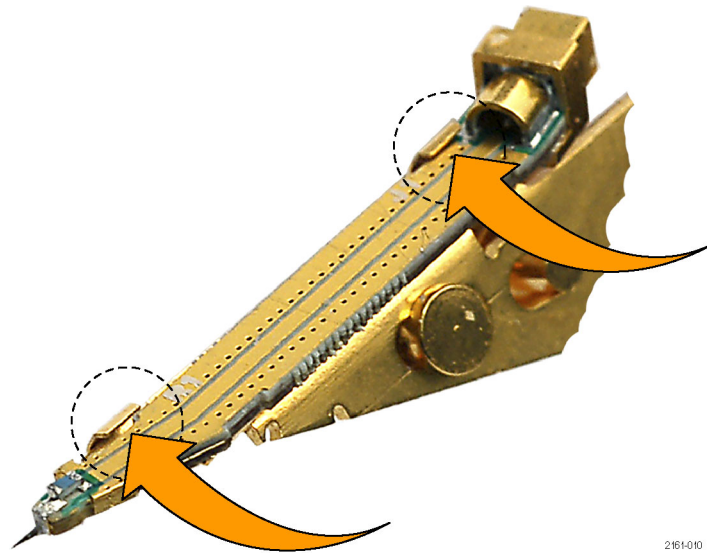

Figure 52: Separating the tip board pair

7. Select the correct board (left or right), and seat the board in the top tabs. The board is notched to align it to the tip body.



2161-010

Figure 53: Seating the tip in the top tabs

8. Press the bottom of the board to snap it past the bottom tabs.

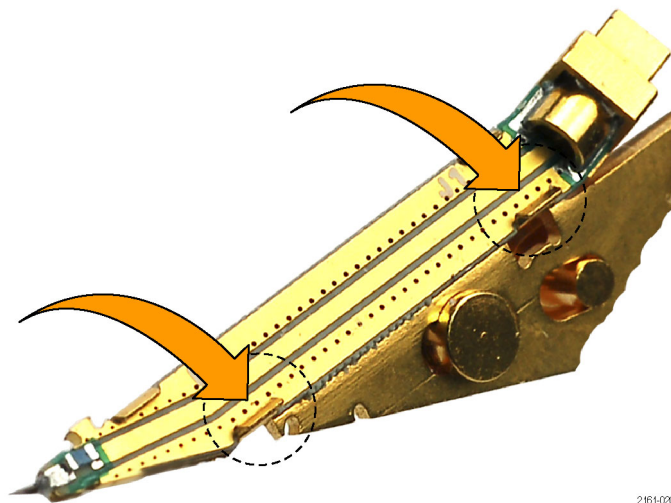

2161-020

Figure 54: Snapping the tip into the bottom tabs

9. Repeat steps 7 and 8 for the other tip.
10. Attach the spring. (See page 40, *P75PDPM Probing Module Springs*.)
11. Reattach the cable pair.

Preparation for Shipment

If the original packaging is unfit for use or not available, use the following packaging guidelines:

1. Use a corrugated cardboard shipping carton having inside dimensions at least one inch greater than the probe dimensions. The box should have a carton test strength of at least 200 pounds.
2. Put the probe into an antistatic bag or wrap to protect it from dampness.
3. Place the probe into the box and stabilize it with light-weight packing material.
4. Seal the carton with shipping tape.
5. Refer to *Contacting Tektronix* on the copyright page of this manual for the shipping address.